

TABLE OF CONTENTS

PART 1	INTRODUCTION.....	2
PART 2	DETERMINING A LOCATION FOR POOL CONSTRUCTION	3
PART 2A	PREPARING THE FOUNDATION FOR AN OVAL POOL	4
PART 2B	PREPARING THE FOUNDATION FOR A ROUND POOL	9
PART 3A	ASSEMBLING THE OVAL POOL BASE AND SIDE BUTTRESSES	11
PART 3B	ASSEMBLING THE ROUND POOL BASE.....	17
PART 4	ASSEMBLING THE POOL WALL AND LINER.....	18
PART 5	INSTALLING THE TOP RAILS AND VERTICALS	24
PART 6	SAFETY INSTRUCTIONS	27
PART 7	USING THE POOL	28
PART 8	POOL MAINTENANCE	29
PART 9	WINTERISING THE POOL.....	30
 ANNEXES:		
A)	INSTRUCTIONS TO USE FOR POOL PAD.....	31
B)	INSTRUCTIONS TO ASSEMBLY AND USE OF THE SKIMMER	32
C)	INSTRUCTIONS TO ASSEMBLY AND USE OF THE POOL LADDER	34
D)	TAKING CARE OF POOL WATER.....	37

Important:

During the pool construction it is necessary to respect the differences between oval and round pools. Where this concerns essential differences, the Instructions are divided into two parts – Part A and Part B. In other parts which are common, the difference in the case of an oval pool is marked through a notice in the text and a “stripe” on the margin of the paragraph in question.

PART 1 - INTRODUCTION

1. READ THE INSTRUCTIONS

Read all instructions completely before you begin.

These instructions explain how to install your pool. Simply follow the step-by-step directions specified in the instructions. Start with this **Part 1** and use the other instructions, i.e. **Parts 2 to 5** to put together your entire pool. **Part 6** includes **Safety Instructions** and **Parts 7, 8 and 9** include instructions to help you keep your pool clean and in good shape, year after year. Be sure to read the **Safety Instructions** carefully and make sure everyone who uses your pool reads and understands them.

Note: The pictures provided for in these instructions may not exactly correspond to your pool. The illustrations serve especially for better understanding the text part. The manufacturer reserves the right to perform changes without a prior notice.

2. PREPARE THE NECESSARY TOOLS AND EQUIPMENT

Before starting the pool assembly, please prepare the necessary tools. You will need:

- A spade, pick, rake, shovel and wheelbarrow for the movement of soil and sand handling;
- A wooden block, about 5 x 10 cm, whose length is longer than one half of the pool, wooden pins, wooden stakes 2.5 x 2.5 cm with a flat upper end and with a length of approximately 15 cm, a bag with flour or fine sand, etc., a ball of twine, knife, spirit level, measuring tape, hammer and nails for the measurement and preparation of a flat foundation;
- Paving blocks for reinforcing the foundation under the pool structure (see Part 2);
- Sieved pit sand for the levelling of the foundation and for the creating of corner filling (see Part 3 of the instructions);
- Phillips screwdriver and a flat bladed screwdriver, combined pliers, textile adhesive tape (for carpets) with a width of 50 mm, if possible, knife, clothes pegs for the pool assembly.

Note: Concerning wooden stakes, we recommend you to pre-bore a sufficiently large and deep hole (See Part 2, Preparing the foundation). Wooden pins may be replaced e.g. with large nails. Before assembling the pool, we recommend you to assemble the stepladder. It will come in handy during the pool assembly, when it is necessary to enter the pool and go out of the pool across the assembled wall. For the ladder assembly instruction see the Annex C.

3. CHOOSE A SUITABLE DAY FOR THE POOL ASSEMBLY

Please wait with the pool assembly for a sunny, windless day. Do not attempt to assemble the pool when wind is blowing. Make sure to have assistance by at least one adult person.

4. REPLACEMENT PARTS AND SERVICING

Should you need advice or if you want to ensure servicing or to obtain a replacement part, please contact your dealer. Use original replacement parts for maintenance and repairs.

5. WARRANTY TERMS

The Warranty Terms and Conditions are provided for in the Dealer's Warranty Certificate.

PART 2 – PREPARING THE LOCATION

DETERMINING A LOCATION FOR POOL CONSTRUCTION

1. TERRAIN

Pay special attention to choosing the right location for your pool:

- Choose a large area of corresponding dimensions and as flat and level as possible.
- Choose a spot with all-the-day sunshine on dry, firm earth — **do not install the pool** on asphalt, tar paper, sand, gravel, peat moss, made-up ground, wood, too wet surface or above such underground facilities as water reservoirs, cesspools, gully holes, etc.
- Check to see that no plant which may grow up through your pool liner is present on the site. If it is the case, we recommend you to treat the site with a total herbicide (according to appropriate instructions) sufficiently in advance before the beginning of the earthwork, possibly to lay a black garden foil under the pool body.
- Sloped areas will need to be made level by digging away high spots, **not by filling low spots**.
- The pool is designed in such a way that it can be partly embedded into earth, when the embedding conditions have been met. The conditions applicable to embedding and professional advice are provided for by the dealer of this pool.

2. PLACES TO AVOID

Do not locate your pool near or on any of the following:

- Near to the areas and objects which are accessible to children or animals and which can facilitate their entry into the pool. Otherwise it is necessary to protect the surroundings of the pool from the entering of children and animals into the pool.
- Grass, stones and roots. Grass will rot underneath the pool liner, and stones and roots will damage the pool liner.
- Near to trees and higher shrubs. Leaves and other impurities are falling directly into the pool and increase its contamination.
- Under overhanging power supply lines and clothes line.
- Areas with poor drainage. The pool area may become flooded with water.
- Areas recently treated with oil-based weed killers, chemicals or fertilizers. In this case it is necessary to use a pool liner made of geotextile.

3. PLAN AHEAD

- Will you be adding an adjacent deck later? Be sure to leave room.
- Be sure that the surrounding vegetation (trees, bushes) will grow and could start to shade your pool.
- Will you be using pool accessories or other appliances that need electricity? Locate your pool in such a manner that it can be possible to install these systems in accordance with safety instructions (see the Instructions for this equipment). Possible installations of electrical sockets and circuit breakers should be performed by appropriately qualified persons only.

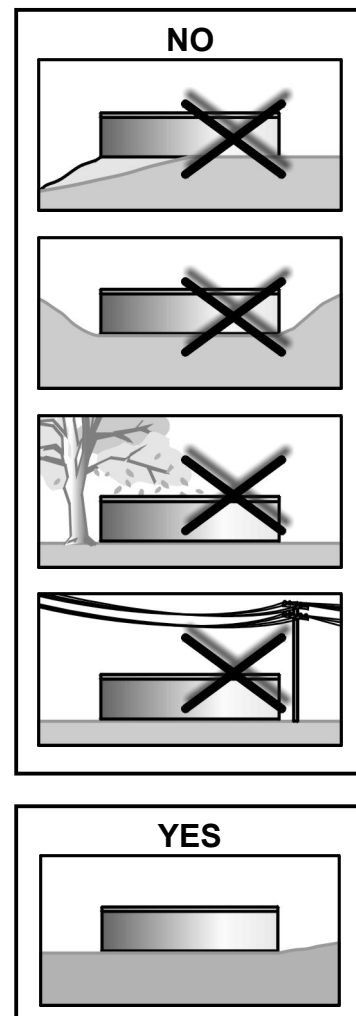

4. PROCEED WITH THE ASSEMBLY ACCORDING TO PART 2A OR PART 2B

Continue to assemble your pool either according to Part 2A for oval pools or Part 2B for round pools.

PART 2A

PREPARING THE FOUNDATION FOR AN OVAL POOL

DIMENSIONAL SKETCHES FOR AN OVAL POOL

Pool size:			
	3.7x5.5 m	3.7x7.3 m	4.6x9.1 m
R	183 cm	183 cm	299 cm
S	200 cm	200 cm	245 cm
L	91.5 cm	183 cm	229 cm
M	91.5 cm	61 cm	77 cm
N	-	122 cm	151 cm
P	183 cm	366 cm	457 cm
T	274 cm	274 cm	320 cm
W	300 cm	300 cm	350 cm
X	183 cm	183 cm	229 cm
Y	205 cm	259 cm	324 cm
Z	314 cm	351 cm	418 cm

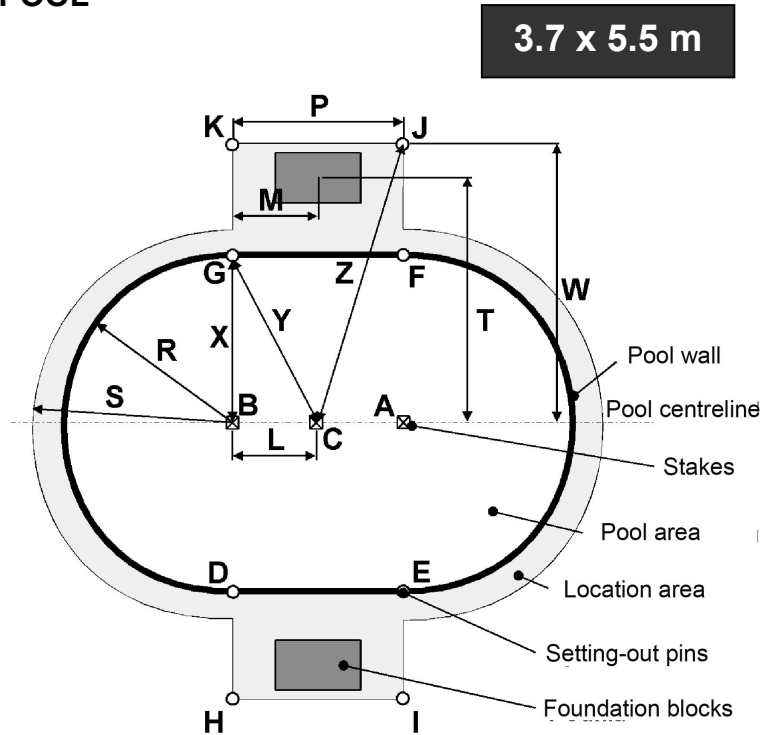

3.7 x 5.5 m

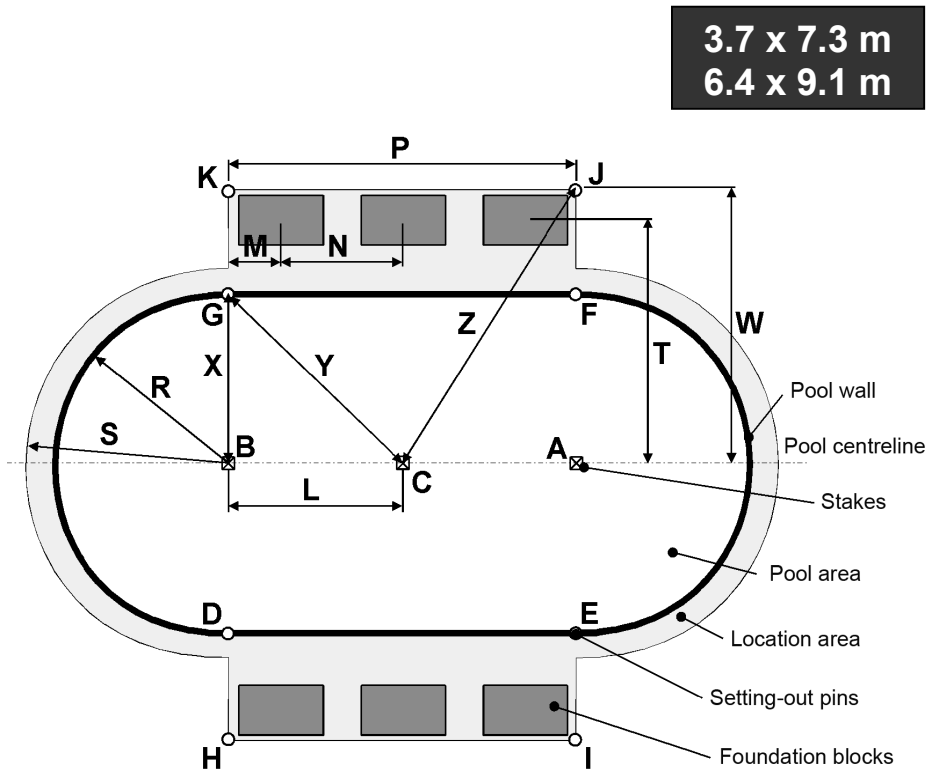

3.7 x 7.3 m
6.4 x 9.1 m

A-B-C ... stakes with a flat upper end
D-E-F-G-H-I-J-K ... setting-out pins

Important: The area under the pool must comply with the following fundamental conditions:

- 1) **It must be levelled,**
This means in a tolerance of maximum 2.5 cm per cross dimension of the pool.
- 2) **It must be provided with a thin layer of sieved sand,**
This means that sand will level small flatness disruptions of the area arising after the use of work tools (pick, hoe, etc.) and will cover the entire area of the pool with a layer not exceeding 2 cm.
- 3) **It must be compacted,**
This means so firm that a person weighing at least 80 kg shall not leave any visible traces on the area.

1. MARK OUT THE AREA

Look at page 4 and prepare the location according to the sketch corresponding to your pool type.

- a. Drive two pins [A] and [B] into the ground (Fig. 2A-1). These pins will both be on the centreline of your pool. The distance between the pins is equal to dimension **P** on the pool drawings (page 4).
- b. Use a length of string tied between pin [A] and a can of sand or lime, flour, etc., and mark a circle on the ground. Next, do the same for pin [B]. Choose the length of string corresponding to dimension **S** in the table on page 4 with regard to appropriate size of the pool. The radius of the circles will be at least 15 cm bigger than the one of the front parts of the pool. (Fig. 2A-2)
- c. Join the two pins [A] and [B] with a piece of string. Use this string as a guide to mark your centreline of the pool.
- d. Replace the two pins [A] and [B] with two flat-topped stakes. Their cross-section should be at least 25x25 mm and their length at least 15 cm. Drive them down flush with the ground surface. (Fig. 2A-3)
- e. Drive another flat-topped stake [C] (of the same parameters) exactly halfway between the two pins [A] and [B] on the pool centreline. Drive it down flush with the ground surface. (Fig. 2A-3)
- f. Join the two circles with straight lines to make an oval. Use setting-out pins and a piece of string as a guide for the marking of the lines (with sand, lime, etc.). (Fig. 2A-4)
- g. Mark rectangles along both straight sides of your oval (Fig. 2A-4). Use setting-out pins and string as a guide to mark straight lines. Use the chart on page 4 to find the correct dimensions **W** for the appropriate size of the pool.

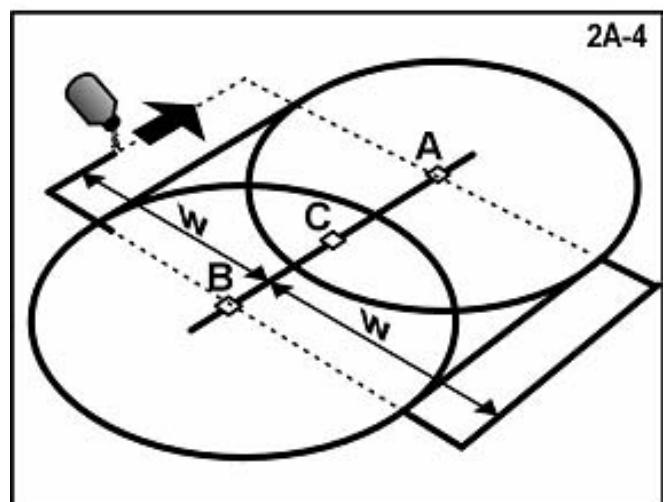
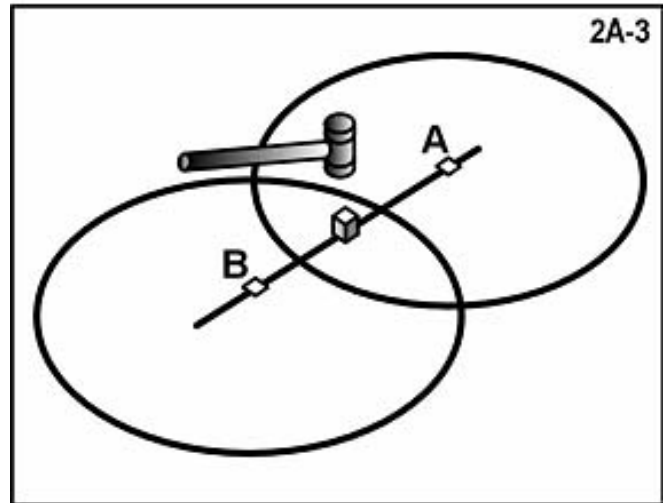
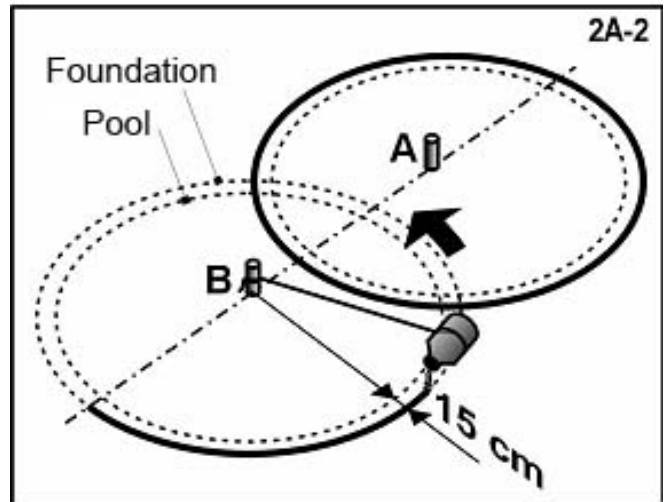
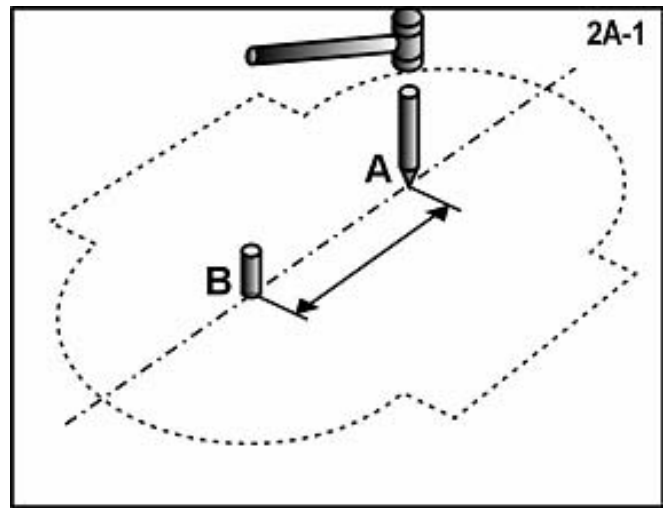

2. REMOVE THE GRASS SODS

- Remove carefully all grass sods and plants from the area marked out, to a depth of 10-15 cm (Fig. 2A-5).
- Remove any sticks, stones and roots from the area marked out.
- If you intend to embed the pool into the ground, it is necessary to perform excavation work to the required depth according to special construction preparation.

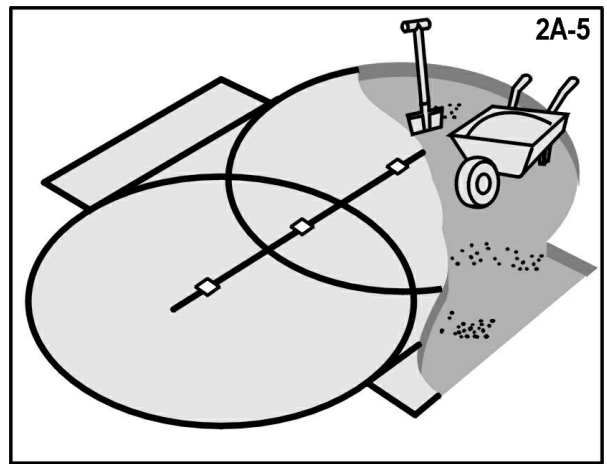

3. MAKE THE AREA MARKED OUT FLAT, LEVEL AND COMPACTED

Remember: Your pool must be perfectly level. Take the time you need to be sure your foundation is perfectly level. A deviation from the level plane must not exceed 25 mm (Fig. 2A-9).

- Drive all three stakes to the ground level and measure them mutually with a spirit level. They must be placed in a level plane.
- Use a 5x10 cm block whose length corresponds to the **S** dimension in the table on page 4 for appropriate size of the pool. Drive a sufficiently long nail into one end. Use the sufficiently long nail to keep the end of the block on the stake when you are rotating the block in the circle (Fig. 2A-7).

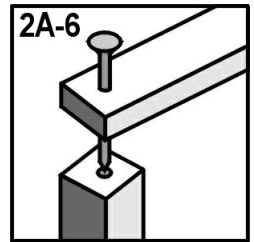

- Drill a hole into the centre of stakes [A], [B] and [C], sufficiently large and deep so that the nail can rotate in it (Fig. 2A-6). It must be possible to pull out the nail from the stake easily and at the same time to make it possible to rotate freely around its own axis.

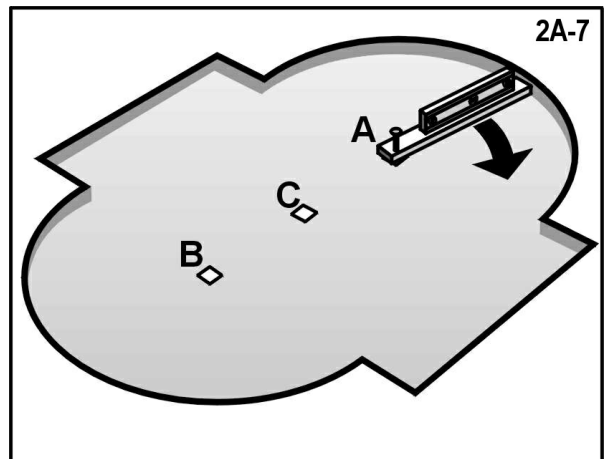

- Now insert the block with the nail into the [A] stake hole. Put the spirit level onto the block and shift the block into the circle around the end driven to the stake and identify the high spots and low areas this way (Fig. 2A-8).

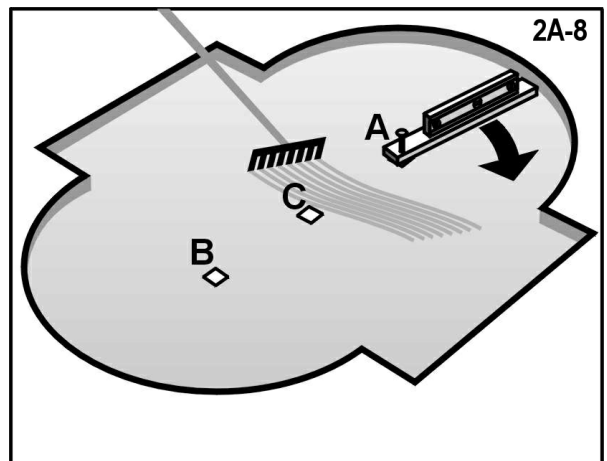

- Remove all the high spots** with a shovel, hoe or rake. **Remember**, your pool must be level within a tolerance of 25 mm across the pool (Fig. 2A-9). If necessary, adjust the height of the stakes [A], [B] and [C] and keep scraping away soil until the area is level.

- Do not fill in low areas** (Fig. 2A-10). Filling will create an unsafe foundation for your pool. Holes from small stones and small dips and hollows may be filled in, but the soil must be hard-packed with a tamping tool.

- Remove the 5x10 cm block from the stake [A] and insert it into the second one [B] and then also into the third stake [C] on the centreline. Repeat steps a. to f. until the whole oval area is level.

- Level the areas marked at lateral sides of the oval in the same manner into the same level as the one of the oval area.

- i. **In order to ensure the future stability of the pool it is now necessary to compact the foundation by using a tamping tool.** A non-compacted foundation can settle down under the pressure of the filled pool and thus cause the pool collapsing. Fill in and compact the low areas and level disruption and compact them.
- j. Check again the surface of the 30 cm of the oval area where the pool wall and areas will be situated next to the direct sides of the oval. Make sure that there are not any high spots or low areas there. The bottom edge of the pool wall must be level flat on the ground and no depressions may be under it.

Hint: Walk on the surface. No traces should be seen on a properly compacted surface.

Remember: The outer 30 cm of the cleared oval area must be perfectly flat (Fig. 2A-11). **The bottom edge of the pool must rest flat on the ground and have no gaps under it.** Take the time you need to be sure this area is perfectly flat, level and compacted.

4. SETTING-OUT PINS

- a. According to appropriate chart on page 4 drive setting-out pins into the points [D], [E], [F], [G], [H], [I], [J], [K]. Measure the distance properly according to the dimensions in the chart. These setting-out pins will help you construct the pool foundation.

Hint: Instead of wooden pins it is also possible to use long nails.

- b. Conduct a string between pins [H] and [I], and between pins [J] and [K].

Important: If you are constructing the pool on a poured concrete slab, do not install foundation blocks as described below. Nevertheless, we recommend to draw the pool centreline on the concrete area and to mark the position of all setting-out pins according to the appropriate dimensional chart. This will make it easier for you to construct the pool foundation.

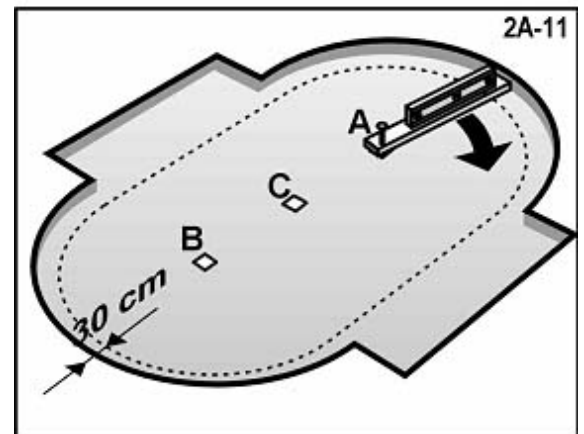
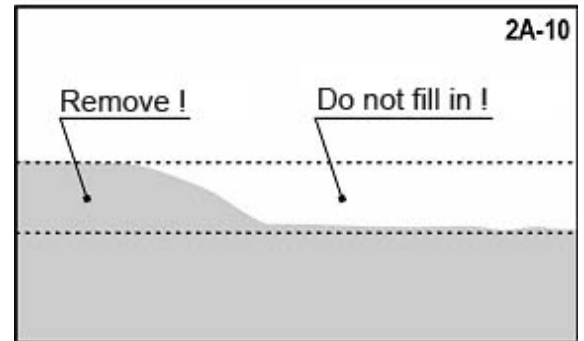
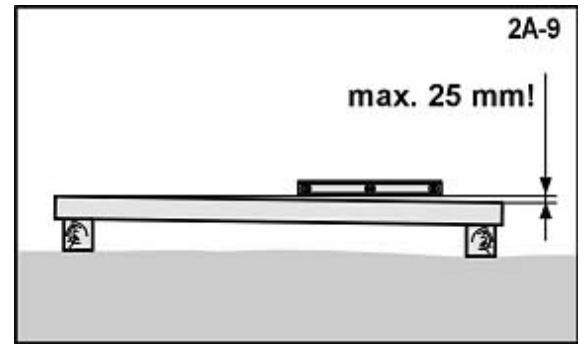

5. FOUNDATION BLOCKS

Foundation block (a concrete paving block) must be laid under each inclined wall buttress in the length of the direct sides of the pool. It is necessary to use the foundation blocks as large as possible, e.g. 50x50x5 cm or 60x40x5 cm.

a. Foundation blocks under the inclined wall buttresses must be installed in such a manner that the distance between the block centre and pool wall can be about 80 cm.

b. According to the dimensional chart of the corresponding pool (see page 4) please mark the ground spots for installation of blocks and make appropriate excavations. Compact the excavation pit bottom. Use a thin layer of sand or finely crushed aggregate as a subbase material.

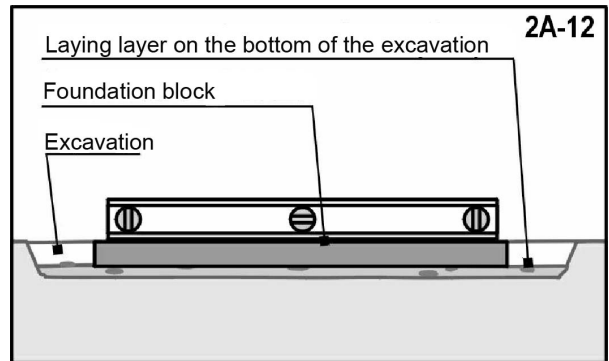

c. All foundation blocks must be embedded into the ground in such a manner that their upper surfaces are flat with the plane of the compacted foundation area of the pool.

d. By using a spirit level make sure that the foundation blocks are perfectly horizontal and flat with the ground (Fig. 2A-12). Use a spirit level placed on the 5x10 cm block to check whether the upper surfaces of the adjacent foundation blocks are in one plane. After the setting of all blocks perform their backfill with sand or crushed aggregate (Fig. 2A-13). Compact the backfill material.

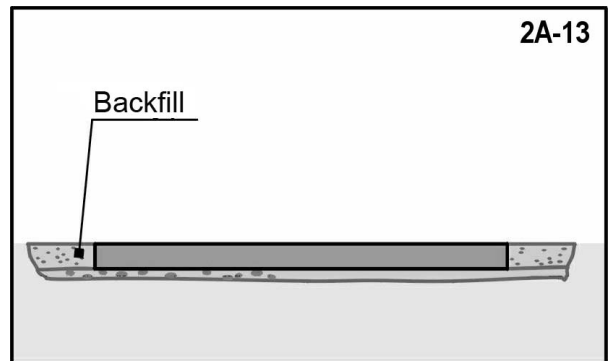

e. In order to increase the stiffness of the foundation, it is possible to place the foundation blocks under the inclined buttresses into the laying layer made of concrete. The excavation must then be approximately twice deeper than the thickness of the paving block used, and on each side approximately 5 cm wider than the block. Use concrete for both the laying layer and backfill.

Important: Level the foundation blocks to one plane between themselves, as described in Step b., before the concrete gets hard. Before proceeding with the pool assembly please wait until the concrete is hard enough.

f. Remove all setting-out pins. Leave the stakes in place for the time being, due to the dimensional checks during construction.

WARNING: Ensure sufficient drainage of the area around the pool in order to avoid the eroding of the foundation.

6. PROCEED WITH THE ASSEMBLY ACCORDING TO PART 3A OF THE INSTRUCTIONS

PART 2B

PREPARING THE FOUNDATION FOR A ROUND POOL

Important: The area under the pool must comply with the following fundamental conditions:

- 1) **It must be levelled,**
This means in a tolerance of maximum 2.5 cm per cross dimension of the pool.
- 2) **It must be provided with a thin layer of sieved sand,**
This means that sand will level small flatness disruptions of the area arising after the use of work tools (pick, hoe, etc.) and will cover the entire area of the pool with a layer not exceeding 2 cm.
- 3) **It must be compacted,**
This means so firm that a person weighing at least 80 kg shall not leave any visible traces on the area.

1. MARK OUT THE AREA

- a. Drive a pin into the ground in the point which should be the centre of the pool (Fig. 2B-1).
- b. Use a length of string tied between the pin and a can of sand or lime, flour, etc., and mark a circle on the ground. The radius of the circle will be at least 15 cm bigger than the one of the pool. (Fig. 2B-2). The length of the string is provided for in the table for the corresponding radius of the pool.

Pool size (diameter)	String length	Block length
4.6 m (15')	250 cm	250 cm
5.5 m (18')	300 cm	300 cm
6.4 m (21')	350 cm	350 cm
7.3 m (24')	390 cm	390 cm

2. REMOVE THE GRASS SODS

- a. Remove carefully all grass sods and plants from the area marked out, to a depth of 10-15 cm (Fig. 2B-3).
- b. Remove any sticks, stones and roots from the area marked out.
- c. If you intend to embed the pool into ground, it is necessary to perform excavation work to the required depth according to special construction preparation.

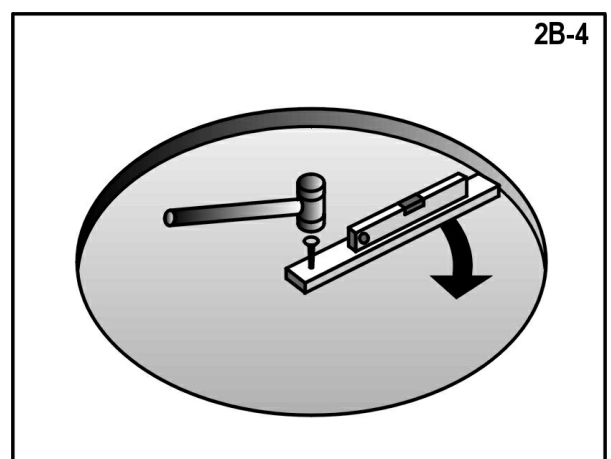
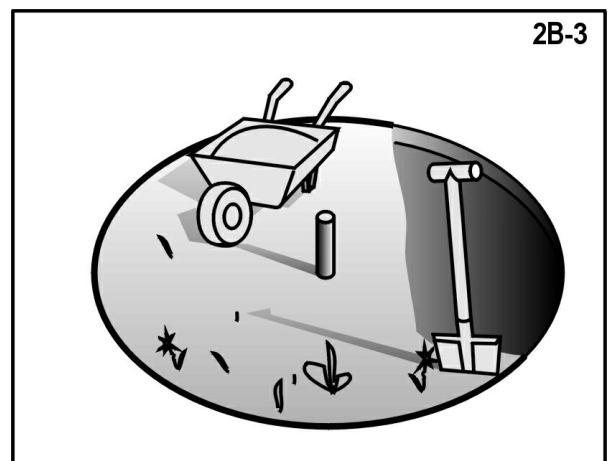
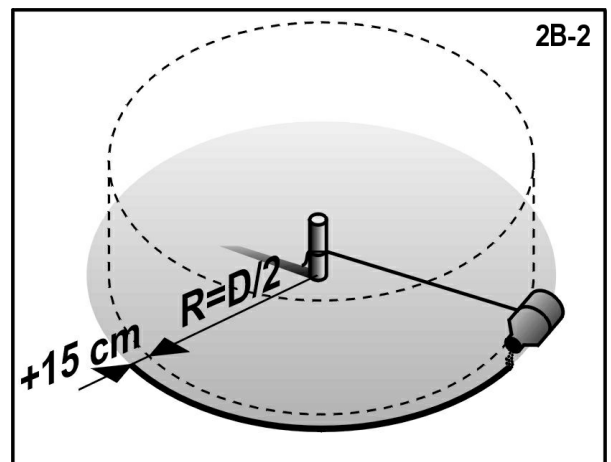
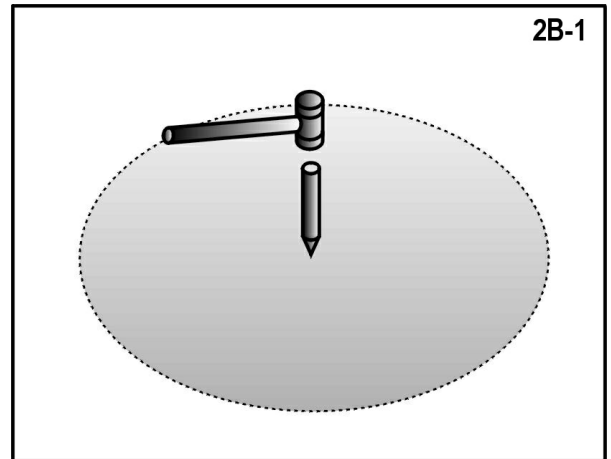

3. MAKE THE AREA MARKED OUT FLAT, LEVEL AND COMPACTED

Remember: Your pool must be perfectly level. Take the time you need to be sure your foundation is perfectly level. A deviation from the level plane must not exceed 25 mm (Fig. 2B-6).

- Replace the pin with the flat-topped stake with a cross-section of at least 25x25 mm and a length of at least 15 cm. Drive it down flush with the ground surface.
- Use a 5x10 cm block whose length corresponds to the size of the pool (see the above table). Drive a sufficiently long nail into one end. Use the sufficiently long nail to keep the end of the block on the stake when you are rotating the block in the circle (Fig. 2B-4).
- Drill a hole into the centre of the stake, sufficiently large and deep so that the nail can rotate in it. It must be possible to pull out the nail from the stake easily and at the same time to make it possible to rotate freely around its own axis.
- Now insert the block with the nail into the stake hole. Put the spirit level onto the block and shift the block into the circle around the end driven into the stake and identify the high spots and low areas this way (Fig. 2B-5).
- Remove all the high spots** with a shovel, hoe or rake. **Remember**, your pool must be level within a tolerance of 25 mm across the pool (Fig. 2B-6).
- Do not fill in low areas** (Fig. 2B-7). Filling will create an unsafe foundation for your pool. Holes from small stones and small dips and hollows may be filled in, but the soil must be hard-packed with a tamping tool.
- In order to ensure the future stability of the pool it is now necessary to compact the foundation by using a tamping tool.** A non-compacted foundation can settle down under the pressure of the filled pool and thus cause the pool collapsing. Fill in and compact the low areas and level disruption and compact them.

Hint: Walk on the surface. No traces should be seen on a properly compacted surface.

Remember: The outer 30 cm of the cleared oval area must be perfectly flat (Fig. 2B-8). **The bottom edge of the pool must rest flat on the ground and have no gaps under it.** Take the time you need to be sure this area is perfectly flat, level and compacted.

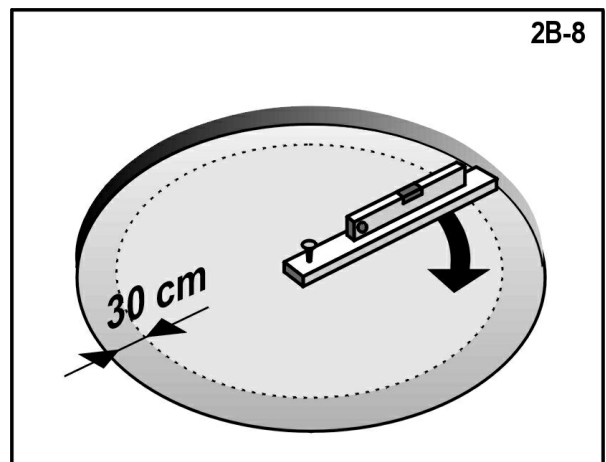
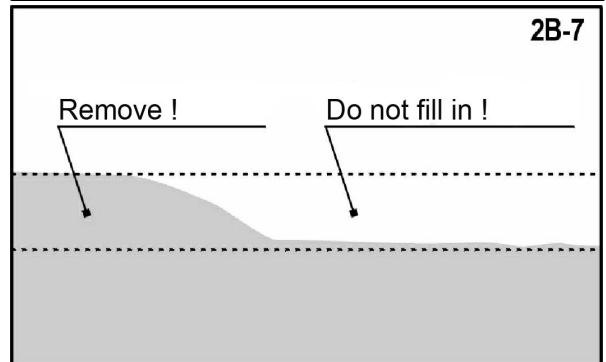
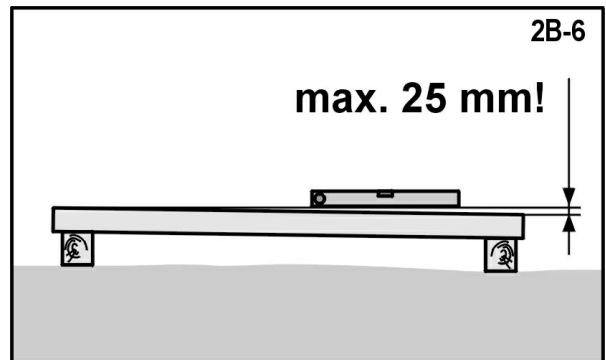
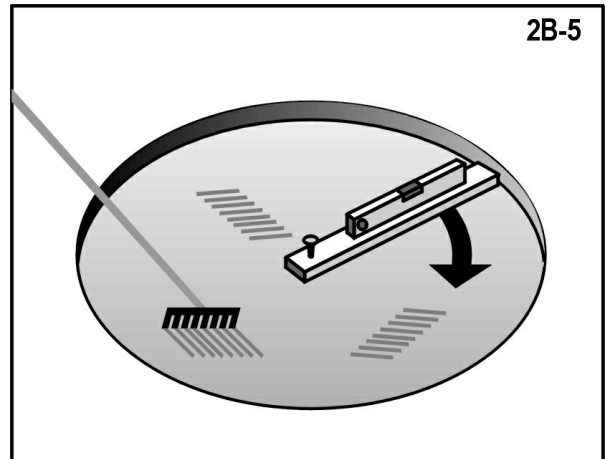

5. PROCEED WITH THE ASSEMBLY ACCORDING TO PART 3B OF THE INSTRUCTIONS

PART 3A

ASSEMBLING SIDE BUTTRESSES OF THE OVAL POOL

1. PREPARING BELTS

- a. Remove the contents from the belt box. Develop the belts [8] and put them on their flat side. Align **finely** all curved and bent parts.
- b. Place the belts [8] in a parallel manner side by side so that the ends of the belts can be placed on the surface area of the foundation blocks (Fig. 3A-1). The end of the belt must be at least 15 cm from the end part of the block (Fig. 3A-2).

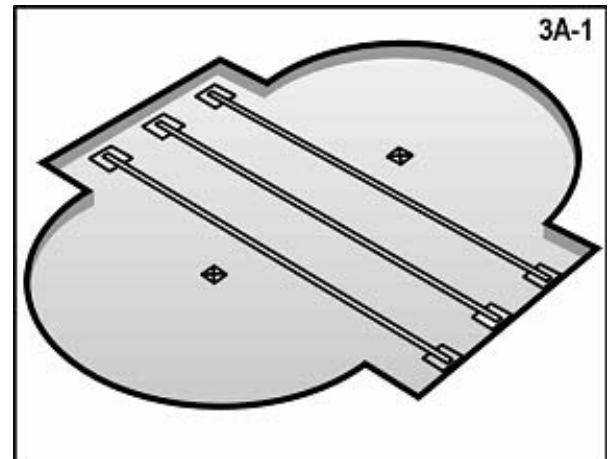

- c. Install the clamp of the inclined buttress [16] on both the ends of all the belts [8], according to Figure 3A-3. Attach it with four bolts [21] and nuts [10]. The bolt heads must be **from below**. Tighten firmly the screw connections.
- d. Make sure that the belts laid are mutually **parallel and levelled**. The distance between the belts correspond to the dimension **N** in the table on page 4 for the appropriate pool size.

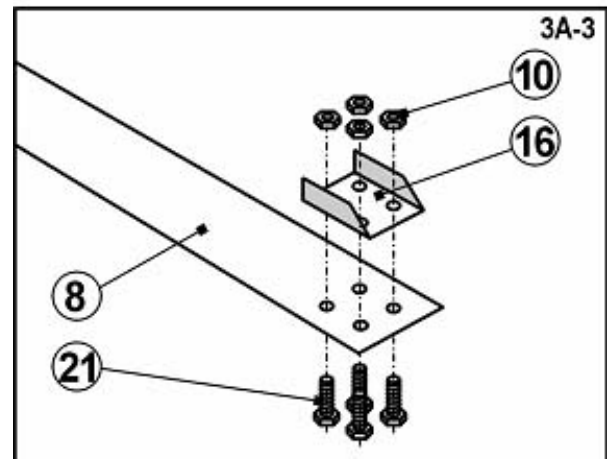
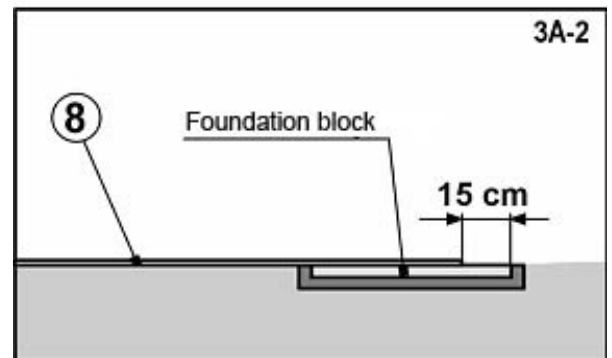

2. INSTALL THE BASE METAL SHEET AND VERTICALS

- a. With the help of a straight edge (you can use base metal sheet) level the surface area on which the base metal sheet will be placed.
- b. Compact the surface area, fill in any possible low areas and compact again. The surface area must be perfectly levelled.
- c. Raise slightly the belt [8] and insert four bolts [21] (Fig. 3A-4) into the holes in the belt **from below**.

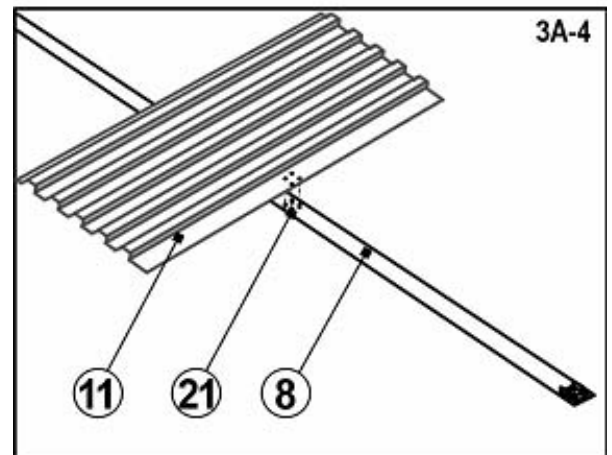

d. Put the base metal sheet [11] and the cup [23] onto the bolts, and screw and tighten the nuts [10] (Fig. 3A-4 and 3A-5).

e. Attach the vertical [9] to the cup [23] and screw both the parts together with the help of bolts [21] and nuts [10] (Fig. 3A-6).

f. Make sure that a clearance of approximately 2 mm (Fig. 3A-7) remained under the side lower edge of the vertical.

g. Firmly tighten the screw connections.

h. Repeat the steps a. – g. for all verticals.

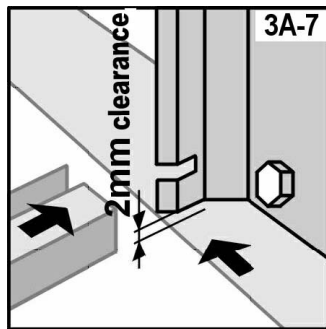
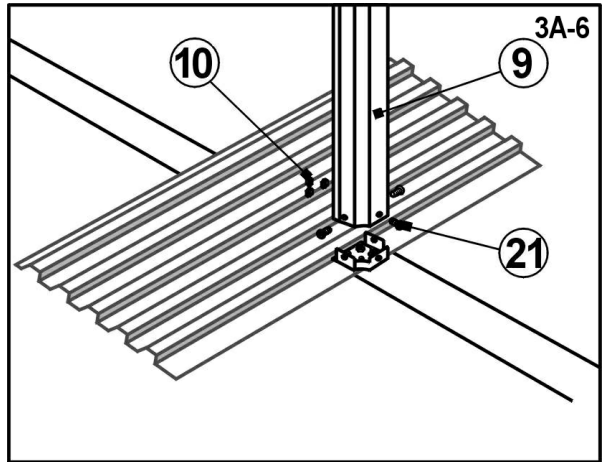
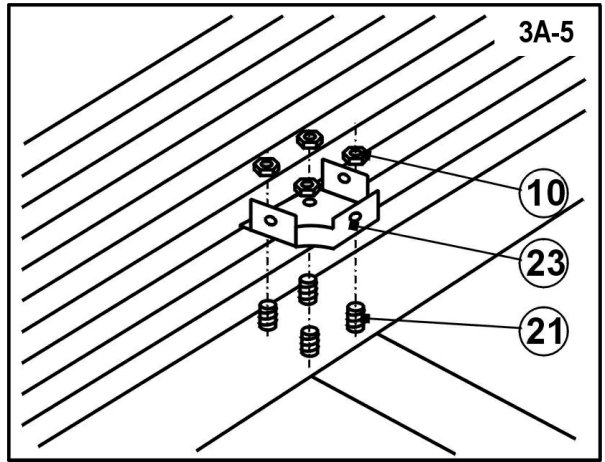

3. INSTALL INCLINED BUTTRESSES

a. Insert the inclined buttress [15] with the locking mechanisms into the holes in verticals [9]. First put the buttress into a horizontal position (Fig. 3A-8) and insert it into the vertical. Then press onto the connection upwards and incline the other end towards the ground (Fig. 3A-9 and 3A-10).

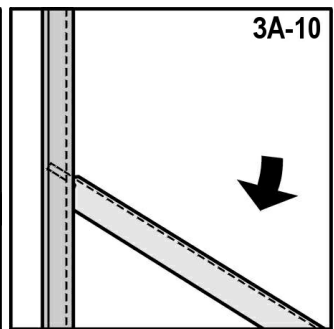
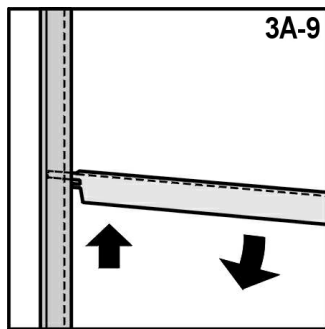
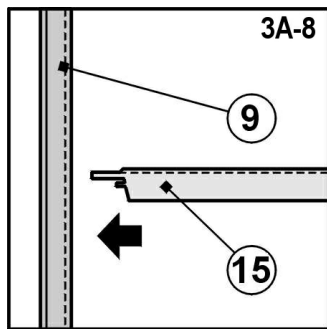

Very important: Ensure continuous pressure upwards on the connection of the vertical and inclined buttress for all the time during which you are inclining the other end of the inclined buttress towards the ground.

b. Align the holes in the lower end of the inclined buttress [15] in one axis with the holes in the inclined clamp [16] attached on the belt end [8]. Put two long bolts [26] (Fig. 3A-11) through the holes aligned this way. Screw nuts [10] onto the bolts and tighten the connections but do not over-tighten them in order to avoid any deformation of the parts.

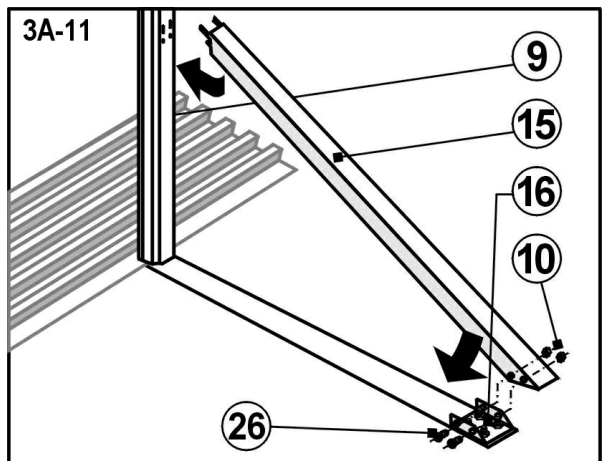

c. Make sure that during installation of inclined buttresses the locking mechanisms in the connection of the vertical [9] and inclined buttress [15] have not released.

4. IDENTIFY LOWER RAILS

Every type of oval pool has different lower rails [13]. These are rails of the A, B, C types and end rails. These rails are identified, for the purpose of an easier identification, with colours and part numbers. Please carry out the identification of the rails and their quantity according to the below stated table and Figure 3A-12.

Pool size	Type C	Type A	Type B	End rail
3.7 x 5.5 m (12'x 18')	none	4 – blue (1460134)	none	6 – without colours (1460061)
3.7 x 7.3 m (12'x 24')	4 – white (1460105)	4 – black (1460135)	none	6 – without colours (1460061)
4.6 x 7.3 m (15'x 24')	2 – white (1460105)	4 – red (1460136)	none	8 – without colours (1460062)
4.6 x 9.1 m (15'x 30')	4 – green (1460033)	4 – red (1460136)	none	8 – without colours (1460062)
5.5 x 10.0 m (18'x 33')	4 – green (1460033)	4 – red (1460136)	4 – yellow (1460064)	6 – without colours (1460063)

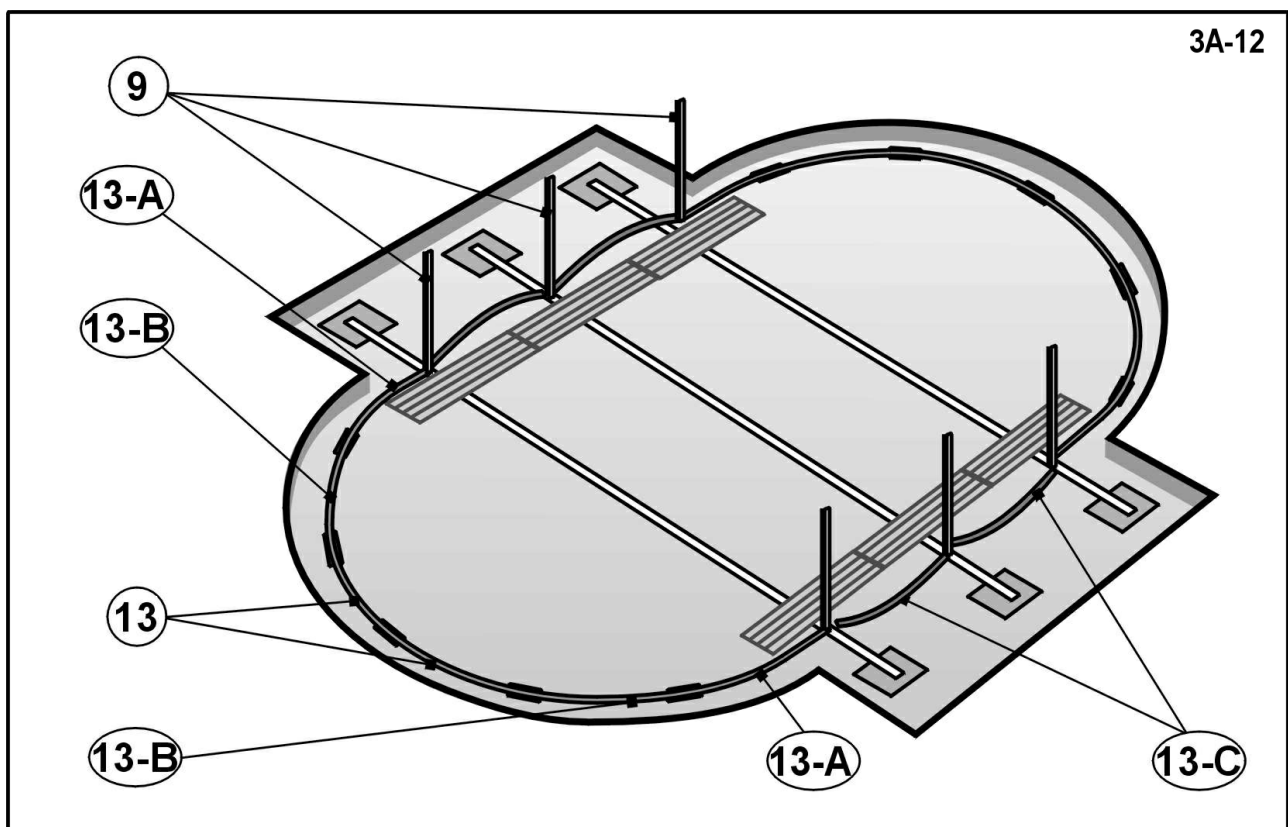

Note: All types of rails are used only for the swimming pool 5.5 x 10 m.

5. INSTALL LOWER RAILS OF THE "C" TYPE

- a. Some pools are equipped with a reinforcement bracing (Fig. 3A-13). In such a case slide the reinforcement into the centre of the C type rail (Fig. 3A-14).
- b. Insert the rounded rail of the C type (Fig. 3A-15) between the neighbouring verticals. Install it exactly in the way as illustrated in Figure 3A-20, i.e. with the groove upwards and inward into the pool, while the upper edge is facing into the cutting of the vertical.

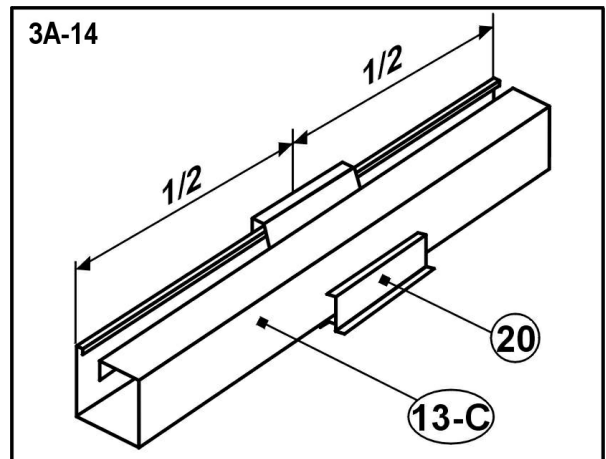
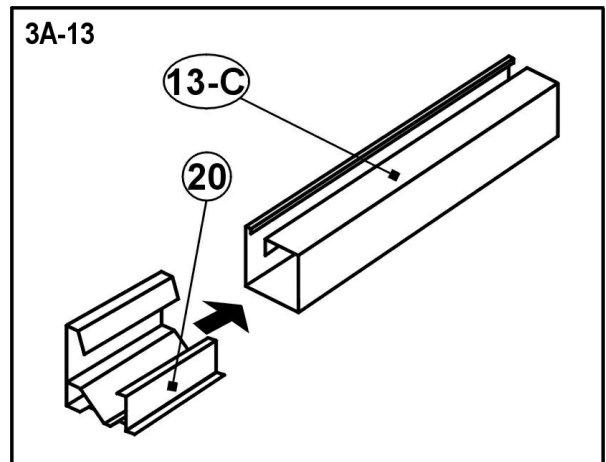

6. ADJUST THE DISTANCE BETWEEN VERTICALS AND THEIR POSITION

- a. In the case of a pool with multiple belts please tie the string between the setting-out pins [D] and [E], [F] and [G].
- b. Now, use the setting-out pins to align the belts in such a way that they can lie in a manner perpendicular to the pool axis, and the vertical in such a manner that they can stand in the same distance from the axis.

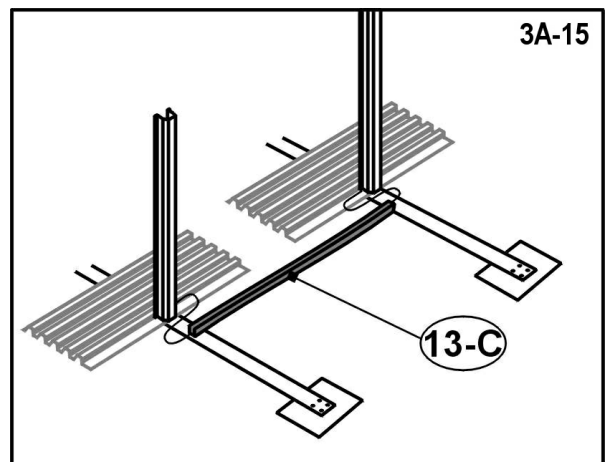

7. ADJUST THE FOUNDATION UNDER BASE METAL SHEET

- Make sure that the base metal sheet lies really in a horizontal manner. If this is not the case, level the foundation.
- Stand on the base metal sheet and fill sand, sandy soil or similar materials (Fig. 3A-16) into the open holes of the base metal sheet. This measure will prevent the occurrence of low areas in the surroundings of the base metal sheet after filling the pool with water.
- Repeat the steps a. to b. for all base metal sheet units.

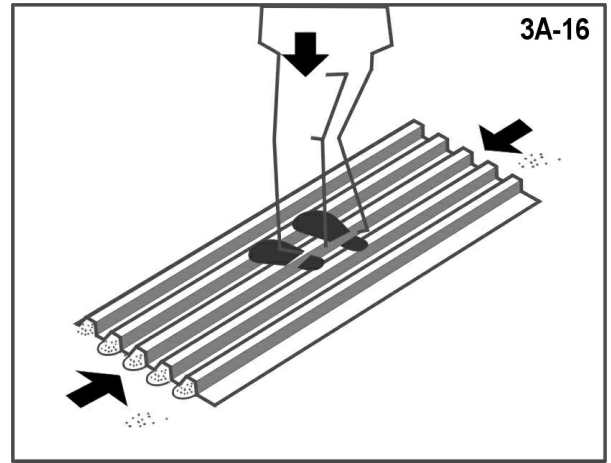

Recommendation: After filling the open holes along the sides of the base metal sheet units, we recommend you to put a piece of firm plastic foil (about 40 x 40 cm) over these holes. This foil will prevent other materials from entering through the holes to the area under the base metal sheet units, and it will eliminate the occurrence of low areas in these places as well.

8. INSTALL TRANSITION RAILS OF THE “A” TYPE

- Install the “A” type rails into the external cut of the end verticals (Fig. 3A-17, 3A-18, 3A-19 and 3A-20). Install them exactly in such a way as illustrated in Figure 3A-20, i.e. with the groove facing upwards and in the direction inwards to the pool and with their upper edge into the cut of the vertical. The label '3A-17' is in the top right corner.

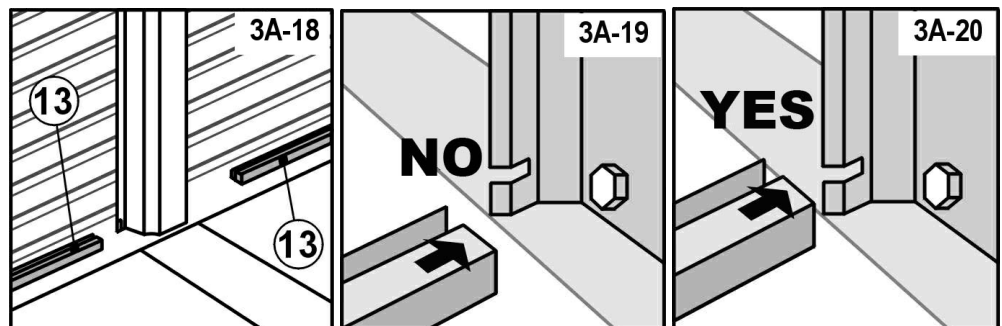
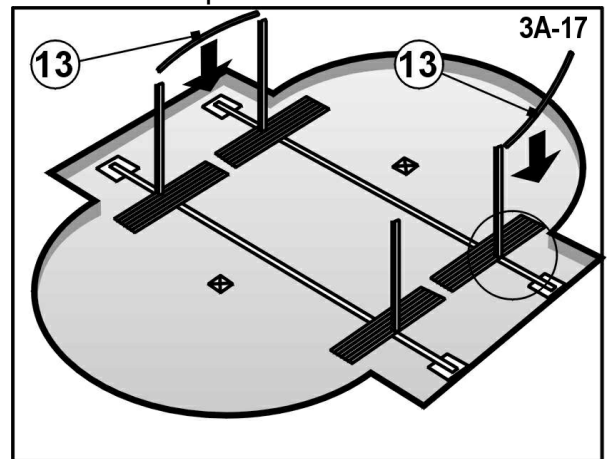

9. DISTRIBUTE THE BASE PLATES AND LOWER RAILS ON HALF-CIRCLE FRONTS OF THE POOL

- Install the connecting piece [2] (Fig. 3A-21, 3A-22 and 3A-23) onto the opposite ends of the "A" type rail [13].
- Then gradually install the remaining lower rails and connecting pieces. Leave a clearance of 55 mm (Fig. 3A-24) between the ends of the rails inserted in the connecting pieces.
- Create a half-circle this way in both the fronts of the pool (Fig. 3-25).
- Use the string to make sure that the connecting pieces are situated at the right distance from the stakes [A] and [B].

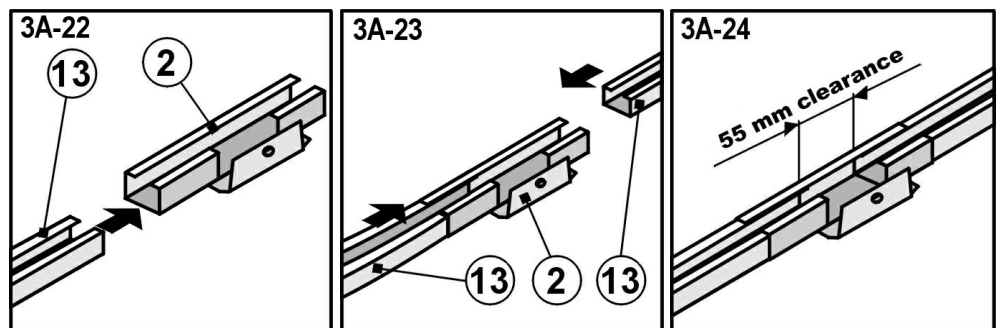
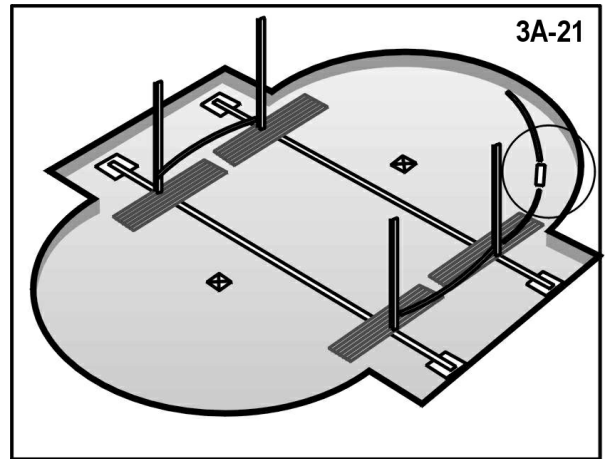

10. SPREAD FINE SAND

- Spread a layer of **not more than 2 cm of fine sand** (stucco sand, if possible) all over the surface of the pool foundation, in order to level the internal surface of the pool and cover the base metal sheet units (Fig. 3A-25). **Do not put sand into the vicinity of the lower rails**, as it could get into the groove of the rail. Leave a strap (width about 10-15 cm) around the lower rails without sand. Align in such a way that the layer can be flat and smooth. Use a rake for this purpose. The area may be sloped towards the centre of the pool.

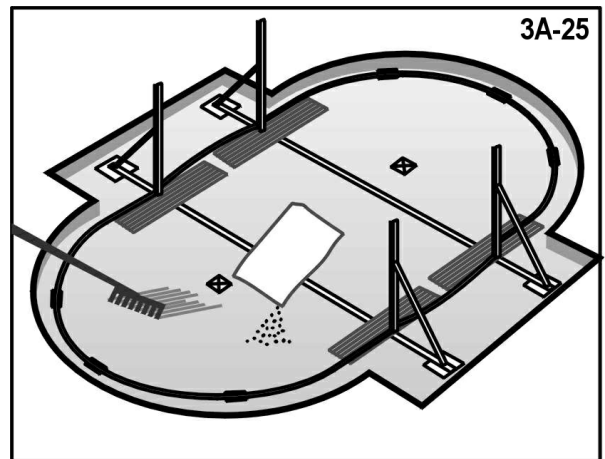

Note: A higher sand layer could have a negative impact on the future pool stability.

- Put about 1.0 – 2.0 m³ of sieved pit sand into the pool area, depending on the pool size. You will need this to create a corner filling (see Part 4, point 6, Shaping corner filling).

Note: While handling the sand, be careful not to damage the lower frame or filling the same with sand.

11. REMOVE THE SETTING-OUT PINS

- remove all setting-out pins

12. PROCEED WITH PART 4 OF THE INSTRUCTIONS

PART 3B

ASSEMBLING THE FOUNDATION OF A ROUND POOL

1. DISTRIBUTE THE BASE PLATES AND LOWER RAILS ALONG THE CIRCUMFERENCE OF THE POOL

- Connect the curved lower rails [13] with the help of connecting pieces [2] and create the round lower frame of the pool this way (Fig. 3B-1, 3B-2 and 3B-3).
- Leave a clearance of 55 mm (Fig. 3B-4) between the ends of the rails inserted in the base plate.

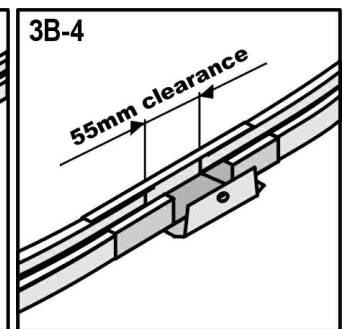
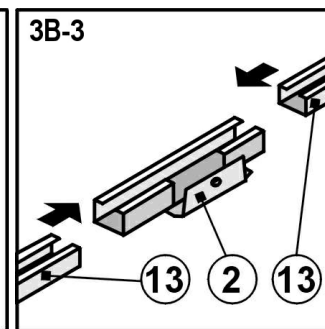
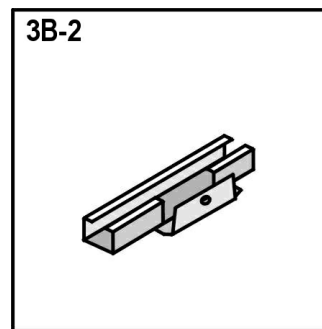
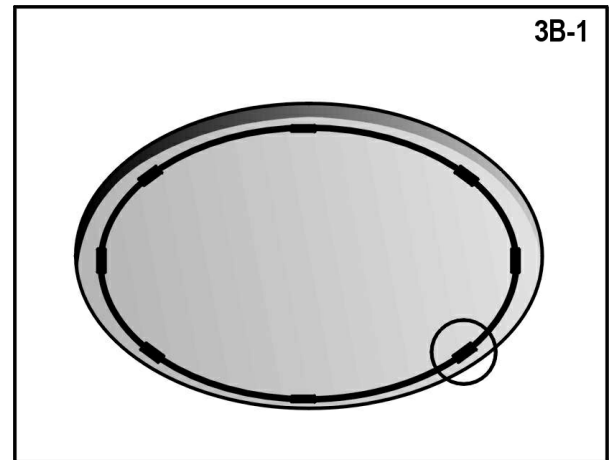

2. SPREAD FINE SAND

- Spread a layer of **not more than 2 cm of fine sand** (stucco sand, if possible) all over the surface of the pool foundation, in order to level the internal surface of the pool and cover the base metal sheet units (Fig. 3B-5). **Do not put sand into the vicinity of the lower rails**, as it could get into the groove of the rail. Leave a strap (width about 15 cm) around the lower rails without sand. Align in such a way that the layer can be flat and smooth. Use a rake for this purpose.

Note: A higher sand layer could have a negative impact on the future pool stability.

- Put about 0.3 – 0.6 m³ of sieved pit sand into the pool area, depending on the pool size. You will need this to create a corner filling (see Part 4, point 6, Shaping corner filling).

Note: While handling the sand, be careful not to damage the lower frame or filling the same with sand.

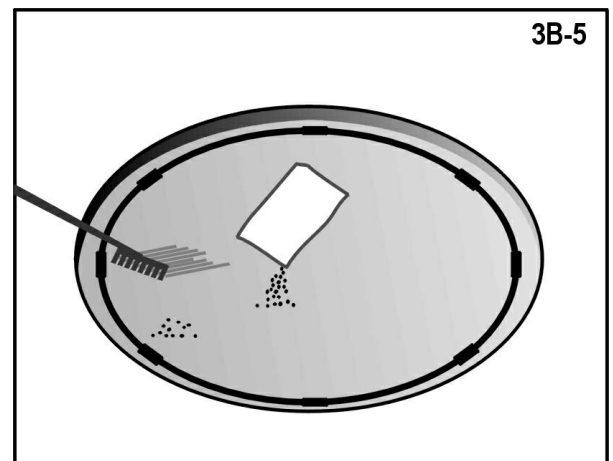

3. PROCEED WITH PART 4 OF THE INSTRUCTIONS

PART 4

ASSEMBLING THE POOL WALL AND LINER

1. ASSEMBLE THE POOL WALL

- a. Please wait with the pool assembly for a sunny, windless day. Do not attempt to assemble the pool when wind is blowing. Make sure to have assistance by at least one adult person.
- b. Unwrap the wound pool wall and place it in the middle of the pool on a piece of plywood (Fig. 4-1). The pre-punched holes for the skimmer must be situated on the top part of the wall.
- c. In the case of an oval pool, please unwrap and split the longitudinally cut tubes [14] according to point 2 on the following page.

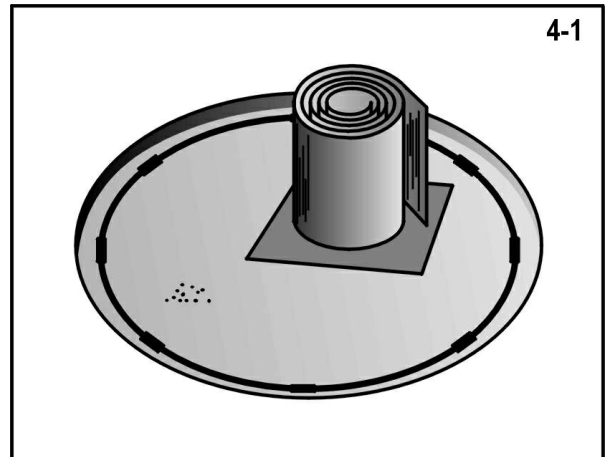

Important: Before unwinding the wall make sure to locate the holes for the skimmer. If they are placed at the beginning of the wall, as illustrated in Figure 4-2, everything is O.K. and you can unwind the wall according to the figure. If this is not the case, the wall was wound in the opposite way during production. In such a case please unwind the wall in the opposite direction than the one shown in Figure 4-2, i.e. in the clockwise direction.

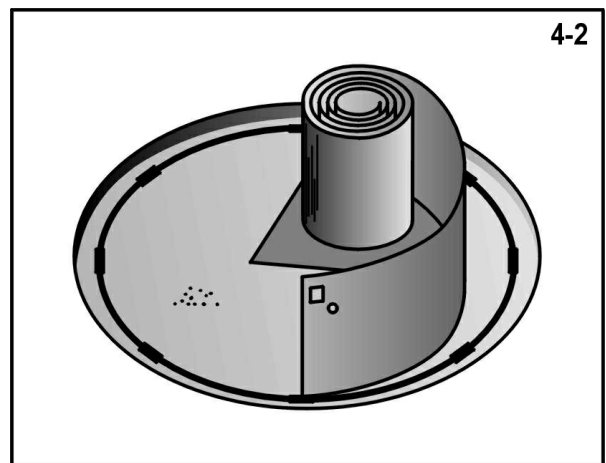

- d. Start to unwind the wall and at the same time introduce its lower edge into the curved lower rail. The beginning of the wall **must** be situated above one **connecting piece** [2] (Fig. 4-2 and 4-3) and the holes for the skimmer and return fitting must be situated at the place where the filtration equipment is to be situated.

Important: In the case of an oval pool, the beginning of the wall must not be situated at the place of the side buttress but only in one of the connecting pieces in the half-circle fronts of the pool.

- e. Unwind the wall and from the upper part install the longitudinally cut tubes [14] (Fig. 4-4). Leave a clearance of approximately 1 cm between individual tubes

Note: In the case of an oval pool, install the tubes according to the table in point 2 and figure 4-5.

- f. Continue around the entire foundation until the entire wall is developed, installed into the lower rails and provided with the longitudinally tubes from the upper part.

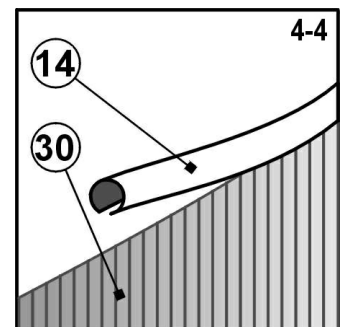
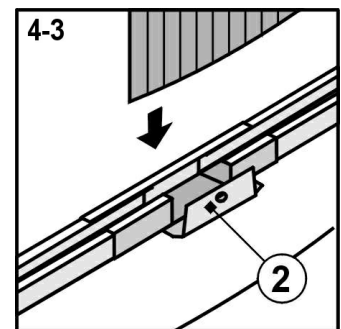

2. IDENTIFY THE UPPER TUBES OF THE OVAL POOL

Every type of the oval pools includes different tubes [14]. These are tubes of the A, B and C types and end tubes. For the purpose of easier identification, these tubes are marked with colours and they are assigned a part number. According to the below specified table and Figure 4-5 please carry out identification of the tubes and their quantity.

Pool size	type C	type A	type B	End tube
3.7 x 5.5 m (12'x 18')	none	4 – blue (1470127)	none	6 – without colour (1470126)
3.7 x 7.3 m (12'x 24')	4 – white (1470105)	4 – black (1470129)	none	6 – without colour (1470126)
4.6 x 7.3 m (15'x 24')	2 – white (1470105)	4 – green (1470100)	none	8 – without colour (1470097)
4.6 x 9.1 m (15'x 30')	4 – green (1470100)	4 – green (1470100)	none	8 – without colour (1470097)
5.5 x 10.0 m (18'x 33')	4 – green (1470100)	4 – green (1470100)	4 – green (1470100)	6 – without colour (1470098)

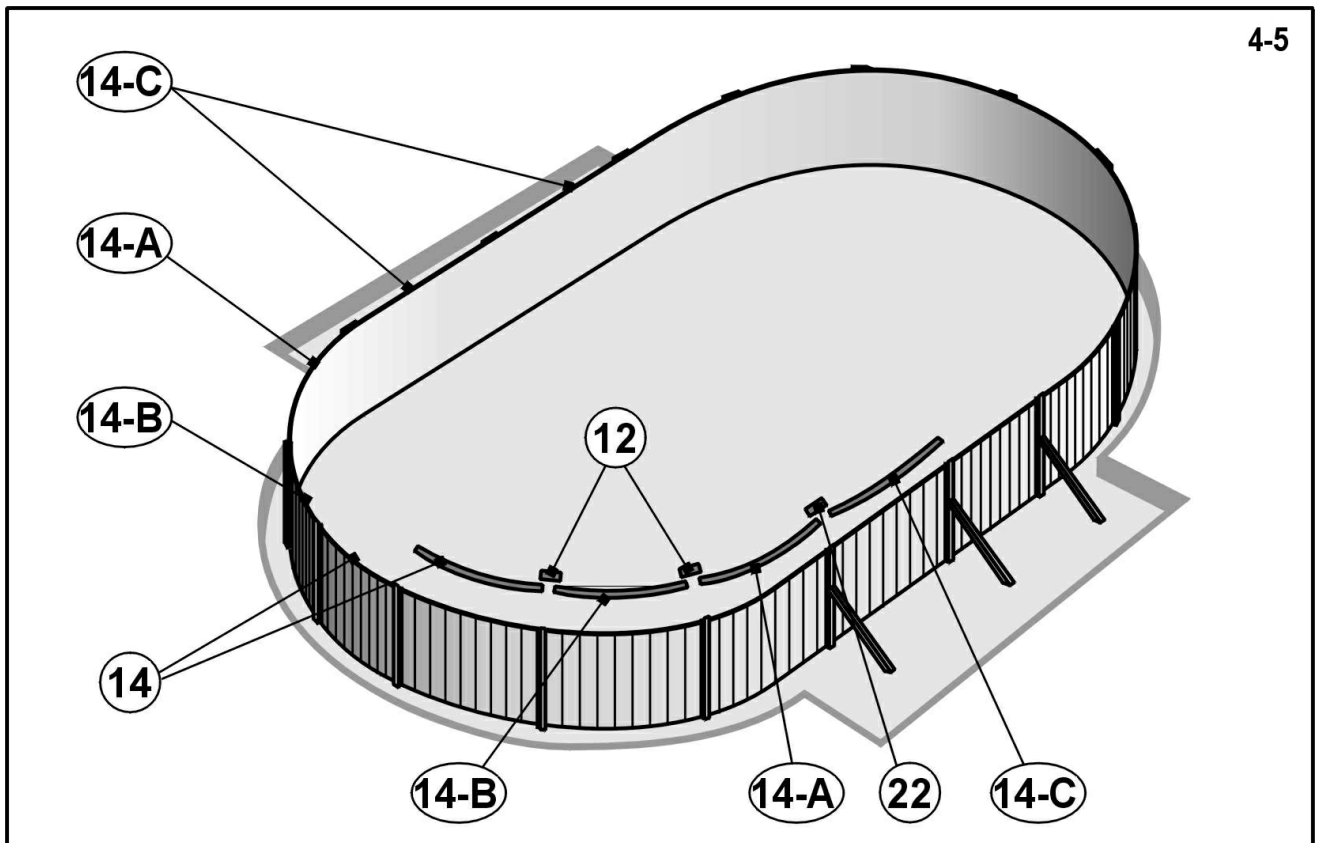

3. CONNECTION OF UPPER TUBES

- Connect the parts of the longitudinally cut tubes [14] on the upper edge of the pool wall with the use of the couplings of the tube [12] (Fig. 4-5).
- In the places where verticals with an inclined buttress are situated (in the case of an oval pool), leave a clearance of about 10 cm between the tubes [14], and connect the parts of the tube [14] by using a plastic insert [22] (Fig. 4-6).

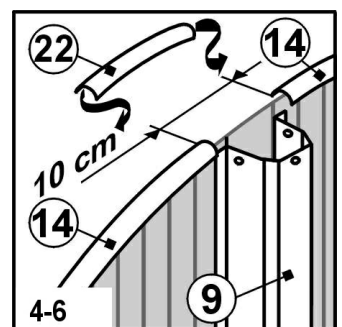

Hint: With the help of a piece of adhesive tape attach each top of the vertical [9] to the wall. By doing so, you can temporarily secure the wall from collapsing during the time before you attach it to the verticals.

Hint: With the help of a piece of adhesive tape attach each coupling of the tubes [12] to the wall. By doing so, it is possible to avoid any undesirable sliding of the tubes from the wall during the liner installation.

4. CONNECT THE POOL WALL ENDS

- a. Align the holes in the two ends of the pool wall against each other (Fig. 4-7).

Hint: Put the screwdriver through two opposite holes in order to facilitate the alignment of the wall end.

- b. In order that the holes can be against each other, make a circle which is formed by the pool wall, the circle should be larger or smaller and make it in such a way that you are pushing the base plates with your foot outwards or inwards to the circle centre.

- c. Connect the ends of the pool wall – insert a bolt **from inside** the pool into each aligned couple of holes, and screw on the nut. The bolt heads are **inside** the pool and all nuts are **outside** the pool (Fig. 4-8).

- d. First tighten the connections in a hand-tight manner. At the end, when all the connections are established, tighten the connections definitely by appropriate tools.

- e. Cover the covering of the wall ends and bolt heads on the inner side of the pool wall by using an adhesive tape (Fig. 4-9), if possible textile adhesive tape.

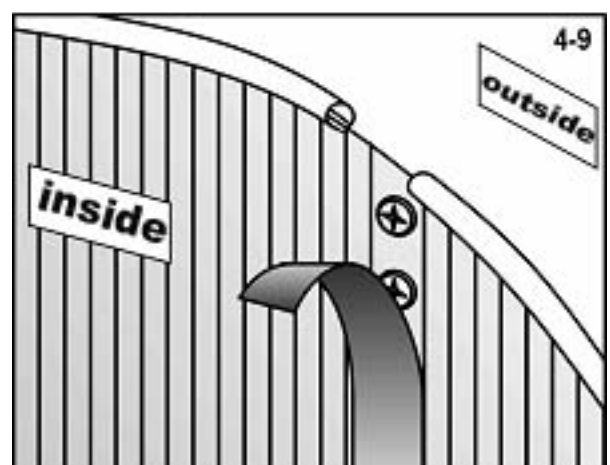
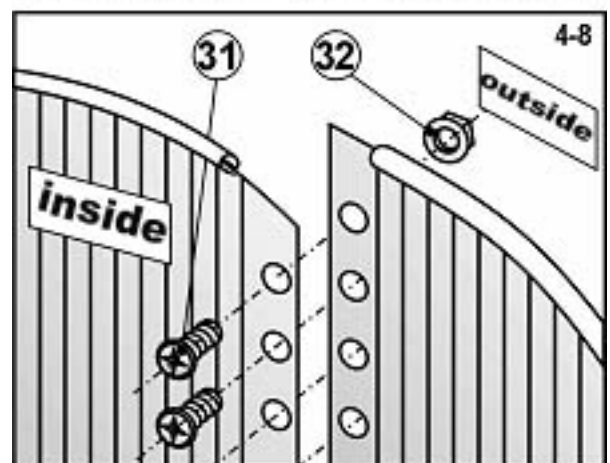
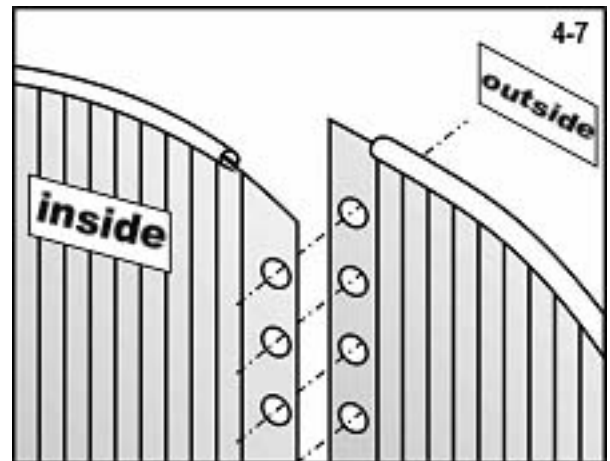

Hint: We recommend you to use the assembled pool step ladder for entering and leaving the pool.

5. CHECK WHETHER THE POOL WALL LIES IN ONE PLANE

- a. Use the tight string with a suspended spirit level (Fig. 4-10) to check whether the opposite upper edges of the pool wall are situated in one plane. Check the wall in several different directions. The wall must stand on a horizontal plane. If the deviation from the horizontal structure is more than 25 mm (Fig. 4-11) on the length expressed by the pool diameter, then put the wall aside and level again the pool foundation into a horizontal plane.

Warning: The pool which is not horizontal is dangerous and may collapse.

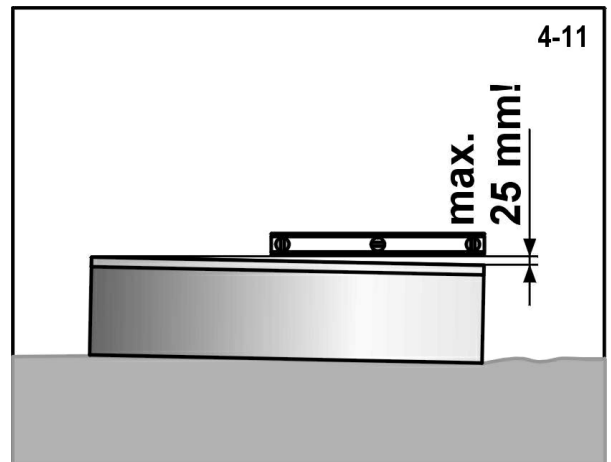
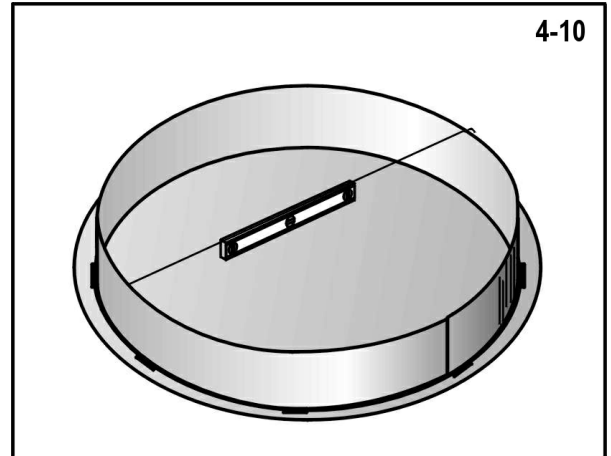

6. SHAPING CORNER FILLING

- a. By using sieved pit sand shape a rounded corner filling which is about 20 cm wide and 20 cm high, at the bottom part of the wall, along the entire circumference inside the pool. Shape the rounding and firmly compact the shape (Fig. 4-12).

Important: At the place of the vertical with an inclined buttress in the case of an oval pool, it is necessary to adjust the size of the corner filling according to the data stated in Figure 4-13. At the same time it is also necessary to ensure that the surface of the base metal sheet is covered with a layer of compacted sand whose thickness is approximately 2 cm. The profile of the base metal sheet units must not rise out of the bottom area.

- b. Now level the bottom surface by using the rake. Be sure to provide continuous transitions of the bottom surface.
- c. Place a geo-textile pad on the pool bottom as the pool liner protection from mechanical damage. For the Instructions to Use see Annex A.

Note: The geo-textile pad for the pool is not included in the pool package. Please contact your dealer.

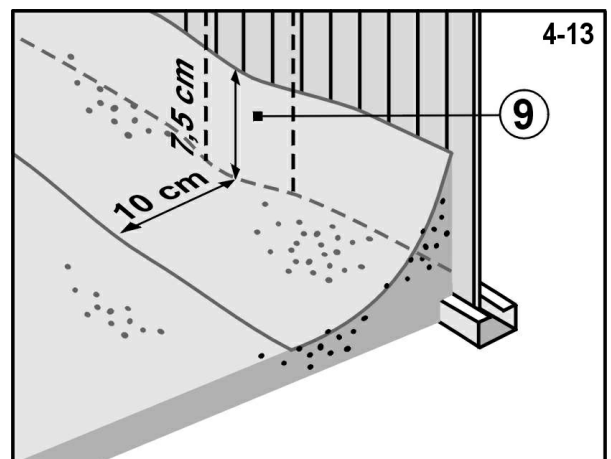
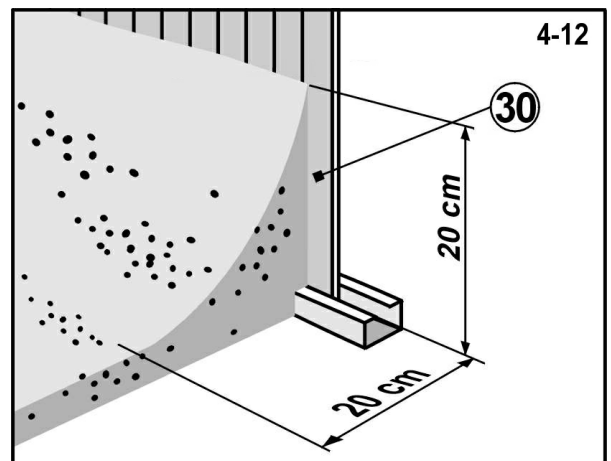

7. PLACE THE LINER ON ITS PLACE

Note: If you intend to use also the filtration equipment together with the pool, it will be necessary, still before the liner installation, to carry out a part of operations of the skimmer installation. read the appropriate Instructions to Installations for the skimmer and proceed according to them. For the Instructions see Annex B.

- Open the cardboard box. **Do not use** any sharp tools to open the box.
- Unwrap and unwind the liner and develop it in the sun so that it can become warm. Check the entire surface of the liner and all seams to verify that they are not broken.
- Spread the liner in the pool in such a way that it can face upwards with the face part of the seams. The arc-shaped seam should be situated in the middle of the corner filling curvature. The other seams will form lines across the pool bottom (Fig. 4-14 and 4-15).
- Smooth the wrinkles of the liner on the pool bottom.

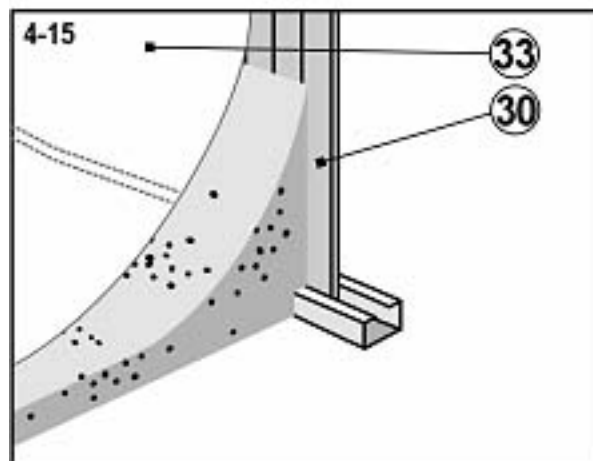
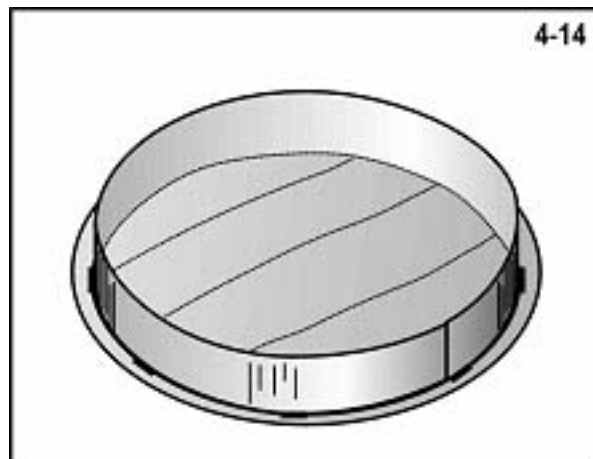

8. ATTACH THE LINER ON ITS PLACE

- Pull the liner over the edge of the pool wall and attach it on site provisionally with the help of several plastic clamping bars (Fig. 4-16). Leave the liner hanging freely for the time being. **Do not tension** the liner too much.
- Start to fill the pool with water. While the pool is being filled, smooth all wrinkles on the liner from the pool centre in circles towards the wall. You can possibly use a fine sweeper. Never press onto the liner by exerting excessive force and do not pull it out. Proceed quickly because already a few centimetres of water can press the liner towards the foundation in such a manner that it will not be possible to move it without damaging it. While working, be sure to keep the arc-shaped seam approximately in the middle of the corner filling (see Fig. 4-15).
- After the smoothing of the bottom please continue to fill the pool and gradually smooth the liner on the wall. Be sure to avoid tensioning the liner and creating an air gap (see Fig. 4-17).

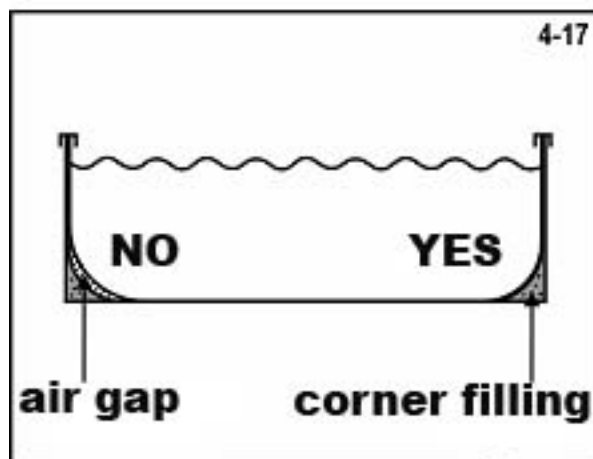
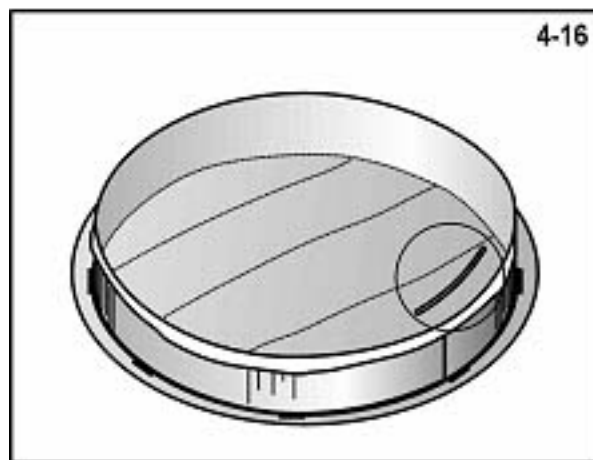

- d. Remove gradually the plastic clamping bars on the upper edge of the wall, **always one piece only** and smooth the wrinkles on the liner. Install plastic clamping bars on the smoothed part immediately after one another (Fig. 4-18).
- e. After having smoothed all wrinkles on the liner, cut away the protruding part of the last plastic bar so that its end can closely sit to the following bar (Fig. 4-19).

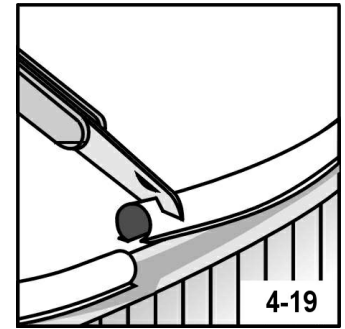
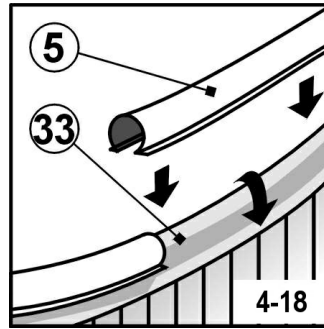

Note: Slight waves on the liner during its installation is natural. It is caused by the play of the vinyl material which protects the liner during its shrinkage.

Note: The liner is not a constructional part of the pool. Its main function is to prevent water from flowing out of the pool. The water pressure is held with the help of walls and structural elements of the pool. The liner must adhere correctly to the ground, corner filling and pool wall, it must never bear the weight of the water which could damage it.

9. PROCEED WITH PART 5 OF THE INSTRUCTIONS

PART 5

INSTALLING THE TOP RAILS AND VERTICALS

1. IDENTIFY UPPER RAILS

Every type of the oval pool includes different upper rails [6]. These are rails of the A, B and C types and end rails. For the purpose of easier identification, these rails are marked with colours and they are assigned a part number as well. According to the below specified table and Figure 5-1 please carry out identification of the rails and their quantity.

pool size	type C	type A	type B	end rail
3.7 x 5.5 m (12' x 18')	none	4 – blue (1450601)	none	6 – without colour (1450182)
3.7 x 7.3 m (12' x 24')	4 – white (1450600)	4 – black (1450602)	none	6 – without colour (1450182)
4.6 x 7.3 m (15' x 24')	2 – white (1450600)	4 – red (1450603)	none	8 – without colour (1450437)
4.6 x 9.1 m (15' x 30')	4 – green (1450605)	4 – red (1450603)	none	8 – without colour (1450437)
5.5 x 10.0 m (18' x 33')	4 – green (1450605)	4 – red (1450603)	4 – yellow (1450185)	6 – without colour (1450184)

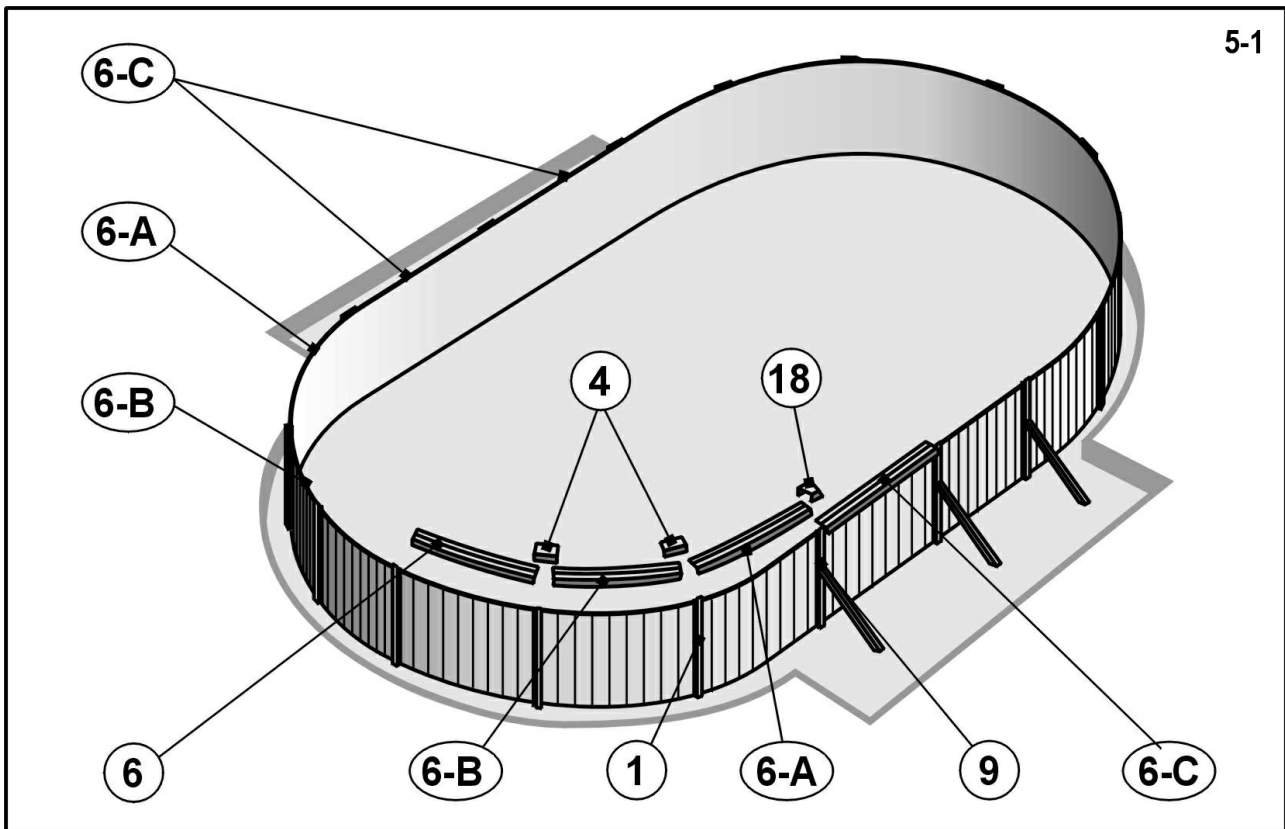

2. CONTINUE TO FILL THE POOL

- a. Continue to fill your pool with water and while doing so, install the upper frame and the pool verticals.

3. INSTALL THE VERTICALS AND UPPER RAILS

Note: In the case of a round pool please skip points a. and b. and proceed according to points c. to h.

a. Install the metal plate [17] onto the upper end of the vertical with an inclined buttress [9] of the **oval pool** and the wall [30]. Align the holes in the plate and vertical so that they can match each other, and screw the two parts together by using self-tapping screws [3] (Fig. 5-2).

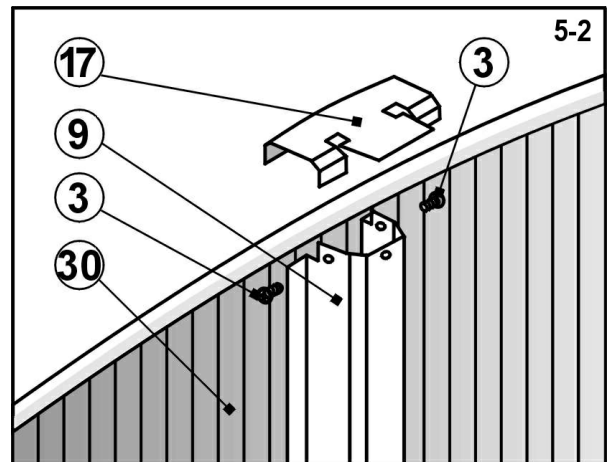

b. Slide the upper rails (Fig. 3) from both the sides onto the metal plate [17], according to the type of the **oval pool** (Fig. 5-3).

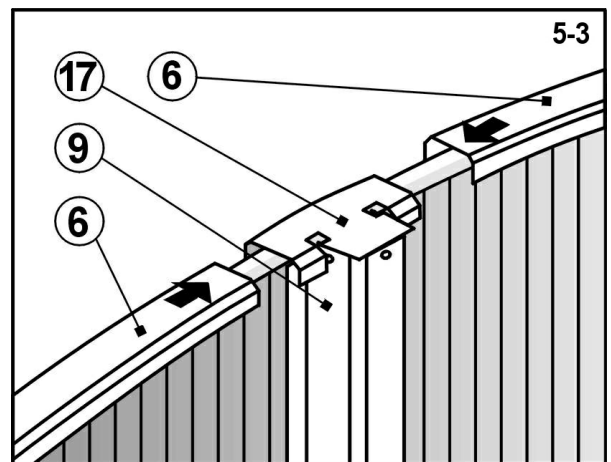

c. Attach and align the bottom part of one vertical [1] in the round part of the pool with the attachment part of one connecting piece [2] (Fig. 5-4). The flap of the attachment part of the connecting piece must be situated **outside** the vertical.

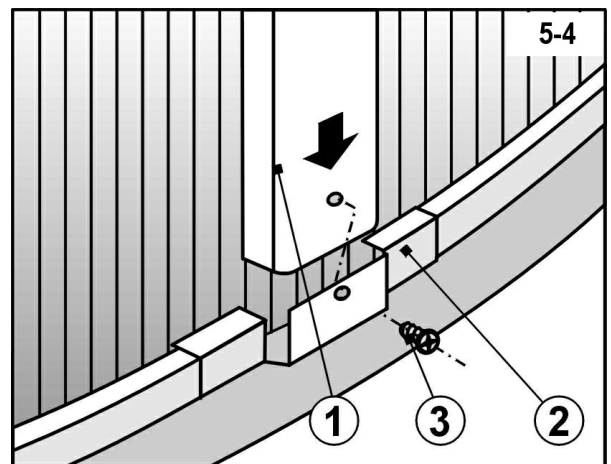

d. Align the hole for the screw in the vertical and the hole for the screw in the flap so that they will match each other and attach the vertical with a self-tapping screw [3] (Fig. 5-4).

e. Place the upper coupling [4] onto the upper edge of the pool wall so that the flap of the attachment part of the upper coupling is situated outside the pool (Fig. 5-5).

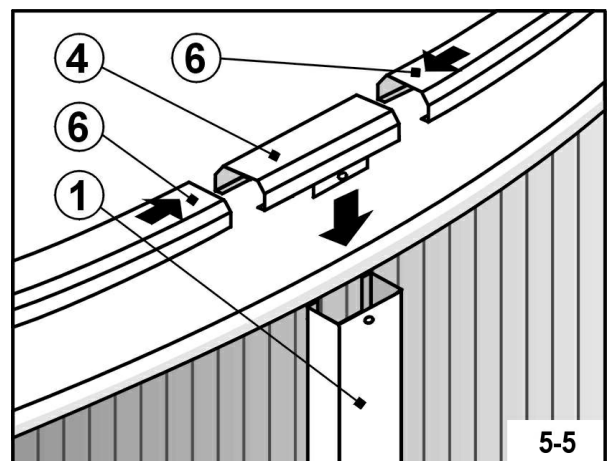

f. Slide one end of the upper rail [6] into the upper coupling [4]. Align the hole for the screw in the flap and the hole for the screw in the vicinity of the top part of the vertical [1]. The flap of the attachment part of the upper coupling must be **outside** the vertical. The vertical must be in a vertical position.

g. Attach the upper coupling to the vertical by means of one self-tapping screw [3]. It will be necessary to develop heavy pressure onto the vertical (Fig. 5-6).

h. Repeat the steps for each vertical along the circumference of the pool wall.

Hint: Use the grooving on the pool wall to check the verticality of the vertical columns.

i. At the end, in the case of an oval pool, install the plastic decorative cap [18] onto the metal plates [17]. Install the cap by using the procedure illustrated in Figure 5-7. Secure the installed cap by using the screw [19] (Fig. 5-8).

Note: The self-tapping screws [19] are 25 mm long, whereby they differ from other self-tapping screws included in the delivery of the connection material. Only these screws can be used for the attachment of the cap.

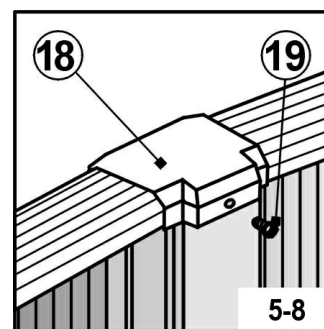
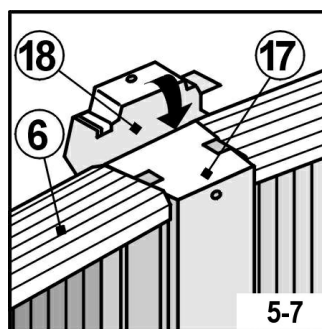
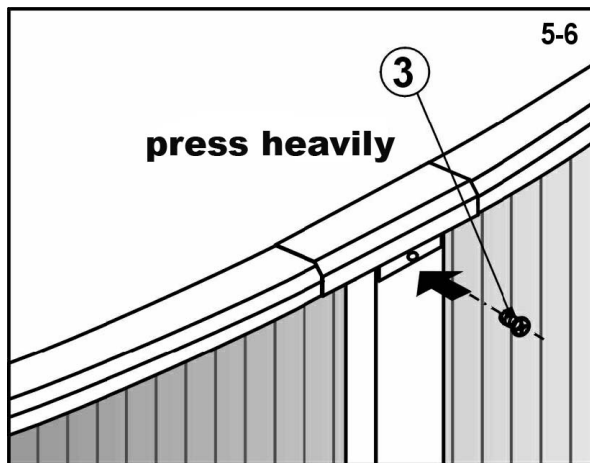

4. STICK THE WARNING LABEL

a. In the vicinity of the place where you want to enter the pool or leave the pool stick the warning label. It is necessary to realise that the pool is not so deep that it can be possible to jump safely into it, as there is a risk of injury.



5. FINISH THE FILLING OF THE POOL

a. Fill the pool with water to a height 5 cm below the lowest hole in the pool wall. Then proceed according to the Assembly Instructions for your skimmer.

Important: While being filled with water, the pool may somehow buckle or shift. This is normal.

b. Attach the filtration equipment to the skimmer installed, according to the appropriate Instructions.

c. Fill water up to the level of the centre of the inflow front plate of the skimmer and carry out the primary disinfection of water (see annex D). Thus your pool is ready for use.

Warning: Before any people start to use your pool, it is necessary for them to read the Safety Instructions and to observe them. The Safety Instructions are included in Part 6.

PART 6

SAFETY INSTRUCTIONS

Your pool contains a large quantity of water, and is deep enough to present inherent dangers to life and health unless the following safety rules are strictly observed. First-time users run the highest risk of injury. Make sure everyone understands all safety rules before entering the pool.

1. No Jumping or Diving



The top rail of your pool is not a walkway and must not be used for jumping or diving. **Do not permit** jumping or diving into the pool from a deck or the top rail of the pool. Diving or jumping into the pool can result in serious injury or even death by drowning.



2. Never use the Pool Alone

Never permit the pool to be used unless it is attended by at least one person other than the bather. Someone should always be available to lend assistance in an emergency.



3. Never Leave Children Unattended

Never leave a child alone and unsupervised in or near the pool—not even for a second. There is no substitute for constant adult supervision.



4. No “Rough-housing”

Do not permit “rough-housing” in and around your pool. Surfaces can become slippery and hazardous when wet.



5. Light the Pool at Night

If the pool is used after dusk, adequate lighting must be provided. Illumination in the pool area must be sufficient to clearly judge pool depth and all features in and around the pool. For lighting recommendations, consult your local licensed electrical contractor.



6. Restrict Access to the Pool

Do not leave chairs or other furniture beside the pool that could be used by a child to climb up into the pool. **Ladders must be removed** whenever the pool is unattended. A fence with a lockable gate around the pool or yard is strongly recommended and may be required by law in some jurisdictions.



7. No Alcohol or Drugs

The use of alcohol or drugs **does not mix** with pool activities. Persons who have been drinking alcohol or using any drugs should not be allowed in the pool, and should be carefully supervised in the surrounding area.



8. Keep Your Pool Clean and Sanitary

The pool water must be regularly filtered and chemically treated so that it can be harmless to health. Use a suitable filter system to remove suspended particles from the water and suitable preparations of pool chemicals according to their Instructions in order to destroy harmful bacteria and eliminate algae formation. Remember, unsanitary water is a serious health hazard.

Warning: Do not modify the pool and do not perform any interventions into the structure of the assembled and filled pool either. It could result in the pool collapsing or in serious injury.

PART 7

USING THE POOL

While using your pool, please adhere to the following instructions so that it can be possible to maintain the pool in a clean and good condition.

1. USING THE POOL

- a. Before entering into the pool take a shower and clean your feet.
- b. Do not enter into the pool with your shoes on, as this means a risk of the liner vinyl foil being damaged.
- c. Use step ladders for leaving the pool. If you leave the pool along the pool walls and if you take off from the bottom of the pool, the internal liner foil could turn down or get damaged in these places.
- d. Maintain the water level in the height prescribed, approximately in the skimmer front plate centre level. Remember that water evaporates from the pool under every weather condition, and that it is therefore necessary to replenish water into the pool. A common evaporation is natural and it should not be confused with water loss due to leakage.
- e. Check the pool and its accessories regularly, to be sure that water does not leak. Repair any possible leakage by retightening or resealing of the connection in question.

2. TAKING CARE OF POOL WATER

- a. The correct care for pool water is one of the most important presumptions in order to keep the pool in an appropriate sanitary condition.
- b. The pool water temperature should not exceed 30°C. An optimum water temperature is about 25°C. Hot water does not make you too fresh, and furthermore it reduces the efficiency of the sanitation substance (chlorine) and forms optimum conditions for algae formation. The high water temperature causes also softening of the pool liner and the risk of wrinkle occurrence on the liner foil. In the case that the pool water temperature achieves 30°C, do not use water heating, remove the cover sheet and possibly replace a part of the water volume with colder water.
- c. The principles for the pool operation and important instructions for the use of chemical preparations are provided for in Annex D.

Warning: In the case of an embedded pool, water is not fully drained off, it is only necessary to reduce the water level within the framework of winterising measures, below the level of the return fitting (see Part 9. Winterising). Complete draining of water should only be performed for the time which is absolutely necessary (as short as possible), and only in the case of repair of defects on the liner foil or if it is necessary to replace the foil. In the case of doubts please contact your dealer.

PART 8 – POOL MAINTENANCE

1. LINER

- a. Check the liner regularly for leaks. A liner with holes may cause water level drops, which may form a cause of damage to the pool or to the filtration unit.
- b. Minor repairs can be made to the liner with a repair kit. Any major damage should be preferably resolved by replacing the old liner with a new one.

2. POOL WALL, VERTICALS AND BUTTRESSES

- a. Keep the pool wall, vertical columns and buttresses clean. Wash them down with mild soap. Do not use abrasives, chemical solvents or cleansing powders.
- b. Wash off any spilled pool chemicals right away.

Warning: Concentrated chlorine may cause damage to the pool liner and metal parts of the pool. Wash down any contamination right away.

- c. Recoat all exposed screw heads and nuts with clear outdoor varnish.
- d. Check regularly all metal parts for possible corrosion, at least once a season. All grooves and corroded areas on metal parts should be treated with a suitable anti-corrosion coating – adhere to the instructions provided on the can with the coating material.

Remember: All corroded areas on the pool wall must be coated in time with an anticorrosion coating. If the pool is heavily corroded it may collapse.

- e. Pay special attention to any leaks at the skimmer and return openings. Leaks must be fixed immediately.

3. POOL STEP LADDERS

- a. For safety and practical reasons do not leave step ladders in the pool uselessly. Use them only for the absolutely necessary period of time when you are using your pool.
- b. The pool step ladders are exposed to the effects of chemical preparations dissolved in the water. That is why it is necessary to check them from time to time, and in the case that you register symptoms of chemical corrosion, coat the concerned parts with appropriate coating.

PART 9

WINTERISING THE POOL

At the end of the swimming season, you must follow these directions to make your pool ready for the winter. While doing so, it is necessary to ensure regular care for pool water, including the filtration system, until the time of winterising.

Be aware: well winterised pool – easy putting into operation of the pool in spring.

1. LOWER THE POOL WATER LEVEL

- a. First adjust the pH value and concentration of the sanitation substance in pool water to the correct parameters.
- b. Clean the bottom from contamination.
- c. Reduce water level in your pool to a level of about 10 cm below the return fitting.
- d. It is necessary to remove the settled materials from the pool wall in the original water level by means of a suitable cleaning agent still before drying.
- e. Treat the remaining water by using a suitable preparation for winterising.

Warning: Do not drain all the water from your pool for the winter, and do not remove the liner. An empty pool can collapse in the winter.

Drain the water from your pool on your own land into grass. In the case of draining water into a land surface water course, it is necessary to discuss this matter beforehand with the appropriate water management authority.

2. CHECK ALL JOINTS AND SCREWS

- a. Make sure all the frame joints are fitting together properly and make sure the pool wall has not shifted from the bottom rail.
- b. Make sure all screws and bolts are tight.

3. CHECK FOR RUST

- a. Paint any scratches or rusty areas with anti-rust paint.

4. CHECK THE LINER

- a. Make sure the top of the liner is still attached to the pool wall with plastic coping. Do not remove the liner from the pool. Removal of the liner will void the existing warranty.

5. FINDING LEAKS

- a. Make sure the liner has no leaks. Leaks in the winter can cause severe damage to your pool.

6. POOL ACCESSORIES

- a. Remove all pool accessories from the pool, including the ladder.
- b. While winterising the filtration equipment, observe the winterising instructions.
- c. Leave the skimmer and return fitting installed on the pool wall.

7. COVERING THE POOL WITH A COVER SHEET

- a. If you have a cover sheet, install it on the pool. By doing so, you will protect the inner part of the pool from penetration of impurities (leaves, seeds, etc.) during winterising.

Remember: Incorrect winterising will cause that the pool warranty becomes void and invalid. Adhere carefully to all the winterising instructions.

Warning: Prevent children, farming animals and pets from accessing to the pool when it is winterised. Do not skate on a winterised pool and do not enter onto the ice! This could lead to liner damage or physical injury.

ANNEXES

A) INSTRUCTIONS TO USE FOR POOL PAD

Note: The pool pad is not a part of the pool package. Please contact your seller.

The unwoven textile “NETEX S” (material for pool pads) is made of the 100% polypropylene staple fibres of a white colour. It is used as a filtration, drainage and separation geo-textile during construction of roads and railways, dump areas, airports, storage and parking areas, etc. It is also used for protection of pool liners and their separation from foundation.

Characteristics of the pool pad

The fibres used for production of the pad are subject to aging in the light after a certain time (known as photo degradation). That is why it is unsuitable to store the pool pad freely. It is necessary to store it in a cardboard box or in the foil which is stabilised from UV radiation.

The unwoven textile is resistant to technical petrol, perchloro-based substances, oil and other chemicals of a similar nature, to fungus growths and micro-organisms. It is health harmless.

Laying the pad for the pool with a corner filling

Install the pool pad after you have assembled the pool wall and made the internal corner filling by using the sieved pit sand. Develop the pad on the bottom inside the pool, centre it and align possible folding pieces. Cut away several centimetres above the corner filling.

While doing so, make sure that no stones or other sharp objects get to the upper side of the pad.

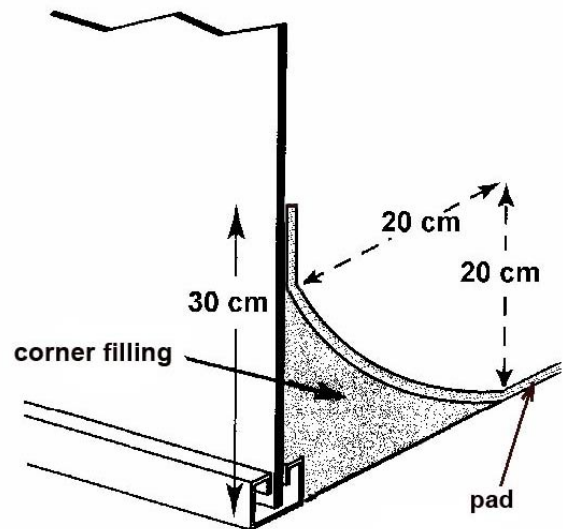

B) INSTRUCTIONS TO ASSEMBLY AND USE OF THE SKIMMER

Note: The level skimmer for removing impurities is not included in the pool delivery. Contact your dealer.

1. USE

The skimmer is used for suction of water from the pool level through a filtration device. Insects, leaves and other floating impurities are drawn into the skimmer and caught in the basket. It is possible to connect a reinforced hose (both 5/4" (32 mm) and 6/4" (38 mm)) to the skimmer.

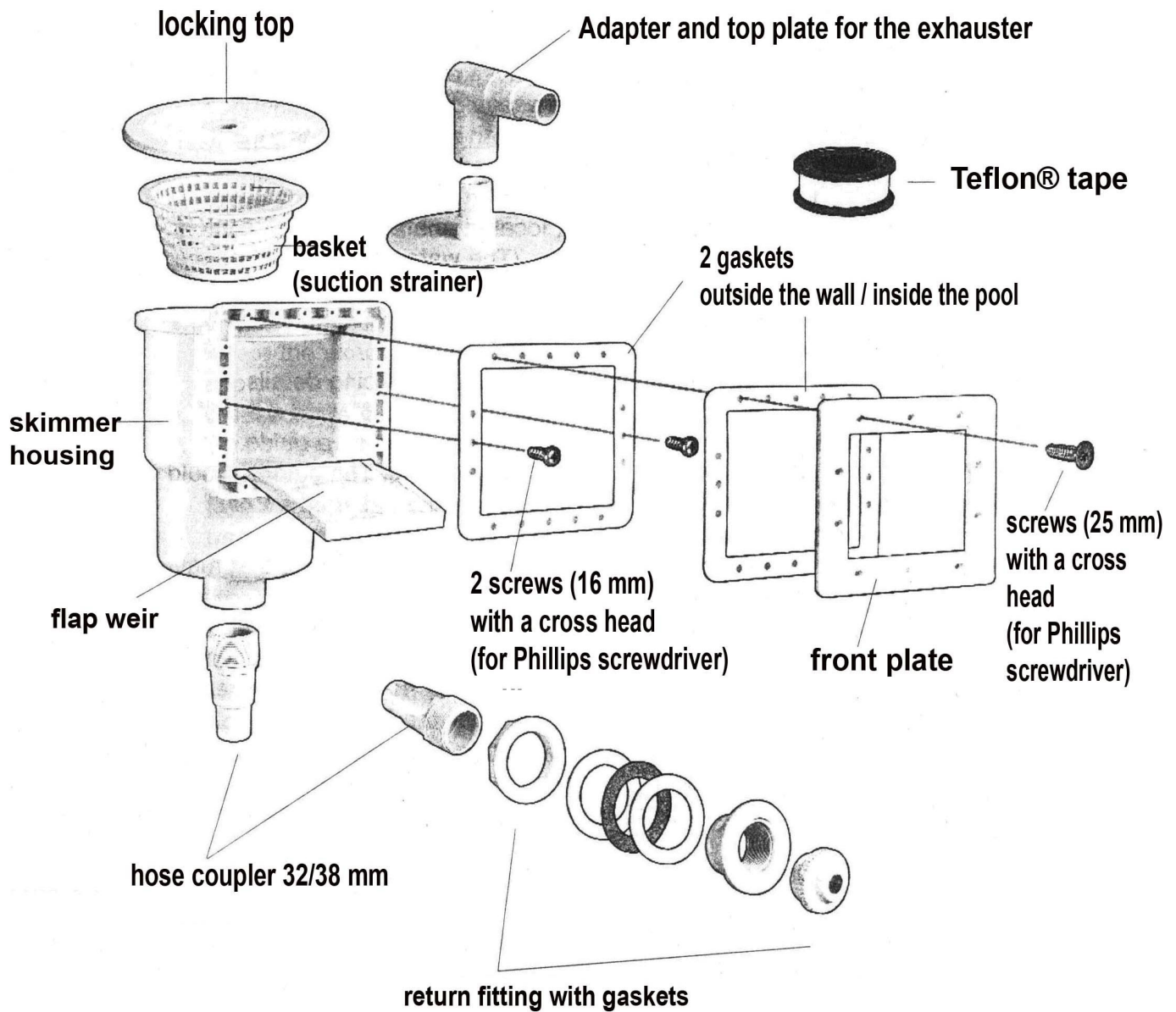

2. ASSEMBLY

Instructions to the skimmer assembly for family aboveground pools

Note: For this assembly you will need a Phillips screwdriver and a sharp-blade knife.

- a. Before installing the liner into the pool punch the holes in the wall, designed for screws and for the holes of the skimmer and return fitting. Smooth and grind the edges of the holes so that they shall not contain any sharp burrs. Install the gaskets delivered together with the pool onto the skimmer hole.
- b. Take one hose coupler and screw it into the skimmer housing. Use a Teflon® tape as sealing (do not use any adhesives or sealing putties).
- c. Before commencing the actual installation it is necessary that the skimmer housing should be already partly screwed to the pool wall. Put one gasket and the skimmer housing to the holes marked out from the external side of the pool. Secure the position by using a couple of shorter screws in central holes along the sides of the skimmer. Before doing so please check for the correct installation of the flap weir in the entry front plate of the skimmer housing. The flap weir must move freely.
- d. And now please install the pool liner and fill the pool with water in such a way that the water level reaches to a height 5 cm below the lowest connection hole of the skimmer (i.e. 5 cm below the return fitting hole).
- e. Use a sharp nail and from the external side of the pool punch the liner in all the holes for the skimmer housing connection. Apply the other gasket from the internal side of the pool and attach the front plate. Insert the remaining 10 longer screws into the holes in the front plate and tighten them gradually by using the Phillips screwdriver.
- f. By using the sharp knife cut the liner out from the front plate.
- g. And now install the return fitting.

Instructions to the return fitting assembly

- a. By using a sharp knife cut out the liner from the external side of the pool wall from the circular hole serving for the return fitting connection. Cut out the hole in the foil about 5-10 mm smaller than the hole in the wall.
- b. Take the other hose coupler and screw it into the return fitting body. Use a Teflon® tape as sealing (do not use any adhesives or sealing putties).
- c. Insert the return fitting into the circular hole in the wall from the internal side of the pool in such a manner that one rubber gasket can be placed from inside the pool and that one cork gasket and the other rubber gasket can be placed from outside the pool. Tighten the return spring properly.
- d. Screw the directional termination piece into the return fitting hole and orient it in such a way that it can face towards the hole of the skimmer.
- e. Interconnect the skimmer and the return fitting with the filtration equipment with the help of hoses. Secure the connections by using the hose couplings.

3. OPERATING INSTRUCTIONS

- a. An optimum water level is in the middle of the skimmer overflow.
- b. Clean the skimmer basket on a daily basis.
- c. The skimmer filled with water must not get frozen. Winterise the pool before the advent of frosts.
- d. The skimmer can be operated also if the pool exhauster is connected – see Annex D, Care for pool water.

Return fitting adjustment

It is possible to adjust the direction of the water stream coming from the fitting – rotate the internal fitting ball into the position required. The water stream should be directed from the skimmer overflow hole. In order to achieve an optimum effect of drawing the surface impurities into the skimmer, it is necessary that the water can “rotate” in the pool “.

4. WINTERISING

Proceed according to the instructions provided for in the Pool Instructions still before the advent of frosts.

C) INSTRUCTIONS TO ASSEMBLY AND USE OF THE POOL LADDER DL-127

Please read carefully the following instructions before the assembly of the step ladder.

- ❑ Read carefully the Assembly Instructions.
- ❑ Determine the place for entry into and exit from the pool. Adjust the length of the ascending arm of the ladder accordingly.
- ❑ The ladder must stand on a firm and smooth surface so that it can be stable.
- ❑ The ladder cannot be used at the same time by more than one person. The **LOAD BEARING CAPACITY OF THE LADDER IS 90 KG.**
- ❑ While leaving and entering the pool on the ladder it is necessary to face it, not to swing and not to waddle.
- ❑ Never dive directly from the ladder and do not jump from it to the pool either.
- ❑ Never swim under the ladder or to the area between it and the pool wall. Risk of drowning!
- ❑ If you do not use the ladder, remove it from the pool. Never leave it in the reach of children.
- ❑ Before using the ladder please check all its parts.
- ❑ In the season when you do not use the pool, we recommend you to clean and dry the ladder and to place it out of the reach of children.
- ❑ Do not use the ladder for any purpose other than the one for which it is designed.
- ❑ People with impaired mobility and little children are only permitted to use the ladder for leaving or entering the pool when accompanied (assisted) by people in full physical and mental capacity.

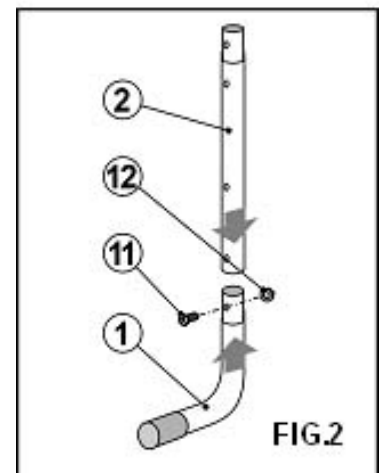
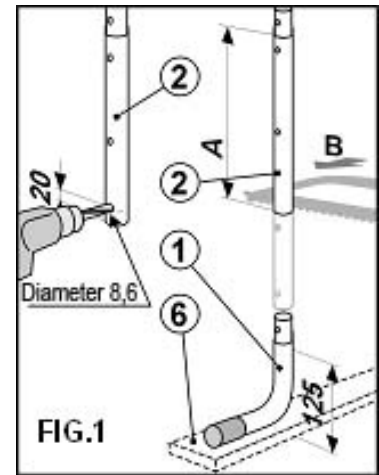

ASSEMBLY

STEP 1: ADJUST THE LENGTH OF STRAIGHT LEGS AND ASSEMBLE THE LEGS

The ladder is manufactured for aboveground pools with a maximum wall height of 123 cm and adapted in such a manner that it can be used, after an easy adjustment also in embedded pools. **If your pool is constructed as an aboveground pool, please continue with step 2.**

LADDER ADJUSTMENT FOR EMBEDDED POOLS:

In order that the ladder can be safe, both the sides (the entry as well as exit ones) must have the same angle towards a horizontal plane. Therefore adjust the length of sectional legs [2], depending on the ladder location, in such a way that the ladder can stand in a straight manner. While determining the length **A** (Fig. 1) it is necessary to count on the arch thickness [1] and the base plate (approximately 125 mm). Measure and mark the cutting place "B".

Prefer measuring twice before you cut the off the legs!

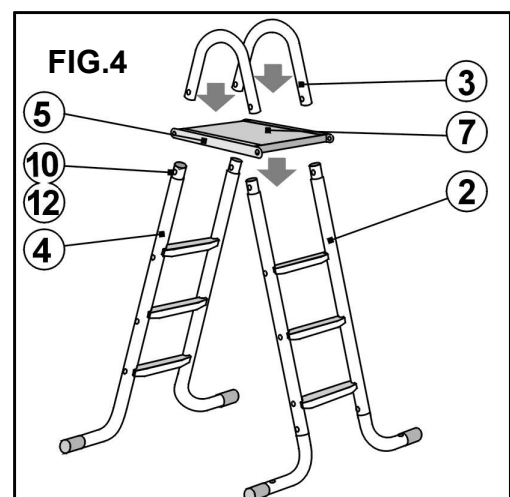
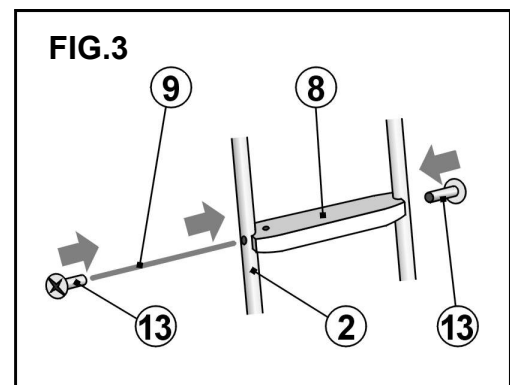

By using a hacksaw cut off the excessive part of legs in the place "B". At a distance of 20 mm from the ends cut off now drill a hole (diameter of 8.6 mm, in any case not more than max. 9 mm) in one plane with the other leg holes.

STEP 2: ASSEMBLE SECTIONAL LEGS AND ARCHES

Firmly press the arches [1] into the two sectional legs [2] and in such a way that the holes in the arches can match the leg holes (Fig. 2). Screw the joints with the help of bolts [11] and nuts [12].

STEP 3: ATTACH THE PLASTIC STEPS TO THE LEGS

Screw one tube nut [13] onto one end of the step stud [9] (Fig. 3). Insert this stud from one side through the hole in the leg [2] or [4] and through the holes on the lower part of the step [8]. The legs must be oriented from themselves at their lower bent (Fig. 4).

NOTE: When the inserted end of the stud gets to the end of the step length, you must press the stud slightly towards the step so that it can pass through the other hole in the step.

Pass the stud through the hole in the opposite leg and screw the other tube nut on this end of the stud. At this phase of assembly please tighten the tube nuts only by hand; do not tighten them with a screwdriver until all the ladder is assembled. The remaining steps are assembled in the same manner as the first step.

At the end tighten all tube nuts with a screwdriver. Do not tighten the nuts excessively in order to avoid cracking of the plastic step.

STEP 4: ATTACH THE LADDER GRAB RAILS TO LEGS

Press the ladder grab handles [3] onto the narrowed ends of legs [2] and [4]. make sure that the holes in the grab rails [3] can match the holes in legs [2] and [4]. Attach the first holder of the platform [5] to the connection of the grab rail [3] and legs [2] and [4], and screw all together with the help of screws [10] and nuts [12]. Do the same on the opposite side, but at first place the platform [7]. Secure the position of the platform by using the bolts [15].

The assembly is illustrated in Figures 4 and 5.

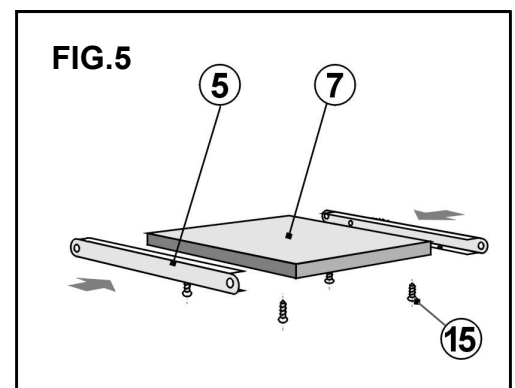

STEP 5: ATTACH THE LADDER TO THE PAD

Before you attach the steps to the base plate, it is necessary to install plastic covers [16] onto the ends of the legs. Take the ladder base plate [6] and place it under the leg arches with a hole (Fig. 6). After the centring of the leg footings on the base plate install the tube nuts [13] from the upper part and tighten them from below by using the countersink screws [14].

NOTE: The tube nuts must be securely tightened, but do not over-tighten them; the parts of the ladders could get damaged due to excessive tightening of tube nuts.

And now your ladder is ready to use.

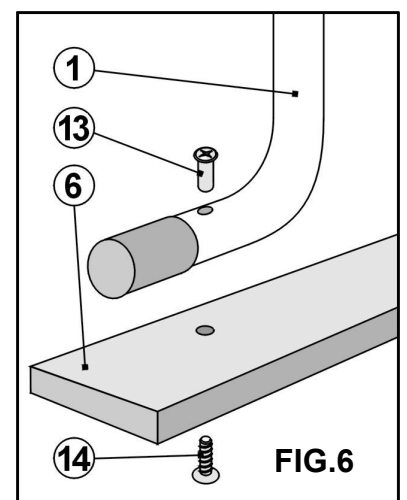

USE

The ladder is designed for the use in aboveground and partly embedded pools. The base plate serves for the reinforcement of the ladder branch structure, which is designed for shortening.

CAUTION: Insert the ladder into the pool in such a manner that the base plate is **out of** the pool – see Figure 7. If you use the ladder in an opposite way, the liner could be damaged by corners or edges of the base plate.

CAUTION: The ladder is not made of stainless-steel materials and therefore corrosion may occur due to chemical agent operation. Therefore please check it occasionally and if you register corrosion symptoms, coat it by using suitable coating.

THE WARRANTY DOES NOT RELATE TO A POSSIBLE CORROSION OF STEEL PIPES!

In the case that you use oxygen-based chemicals for chemical maintenance, the ladder corrosion process is accelerated. In this case it is necessary to treat the part of the steps which will be in contact with pool water, by means of an additional suitable coating layer.

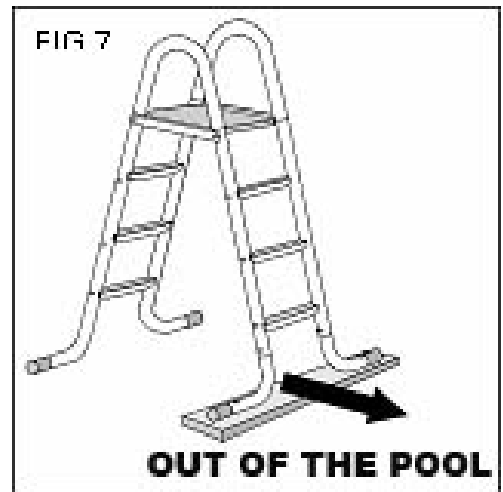

LIST OF LADDER PARTS (DL-127)

POS.	PART NAME	KS
1	Sectional leg arch	2
2	Sectional leg	2
3	Grab rail	2
4	Whole leg	2
5	Platform holder	2
6	Base plate	1
7	Platform 40x44 cm	1
8	Plastic step 40	6
9	Step bolt M6	6
10	Screw M8x35	4
11	Screw M8x30	2
12	Hat nut M8	6
13	Tube nut M6x30	14
14	Countersink screw M6x25	2
15	Countersink bolt 4x16	4
16	Plastic cover	4

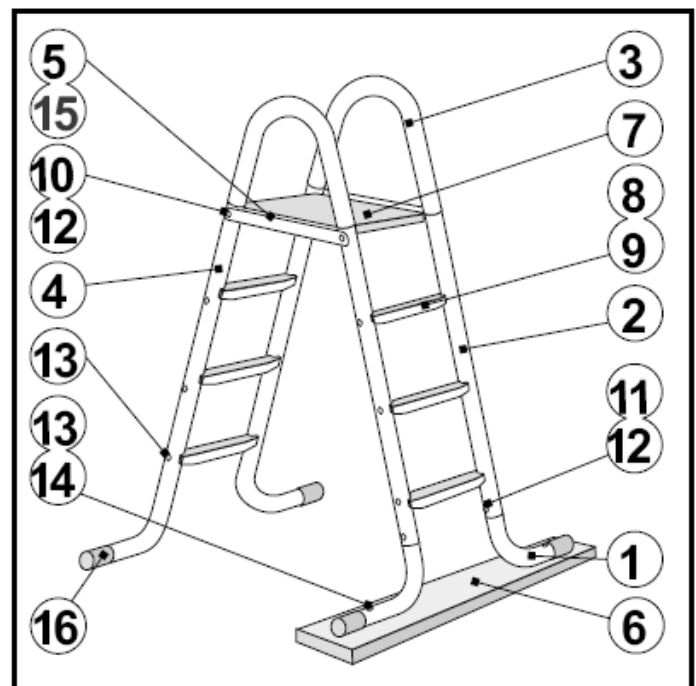

D) TAKING CARE OF POOL WATER

Pool water is not contaminated with visible impurities only (dust, leaves, sand, branches...), but also with micro-organisms (bacteria, algae, fungi and viruses). Even after washing, every swimming person will introduce an unbelievable quantity of impurities into the pool, such as sweat, hair, sebum, residuals of cosmetic and sunbathing creams. A person who has not taken a shower before entering into the pool may bring an unbelievable amount of 600 million to 3.5 billion bacteria, germs and viruses into water. They subsequently form an ideal environment for further bacteria, algae, fungi and viruses. That is why it is necessary to treat water on a regular basis in order to ensure a permanent sanity from bacteriological and health points of view.

MAIN PRINCIPLES OF POOL OPERATION

Filling of the pool – Commencement of operation

Before every new filling, especially after winterising, it is necessary to clean the pool properly from all impurities (lime sediments, dust, organic residuals). Proper cleaning of the pool makes further water maintenance easier.

Fill the pool with water, put the filtration circulation equipment into operation and keep it in operation at least overnight. Remove solid larger impurities by using a basket, and remove sediments on the bottom by means of the pool exhauster. Immediately after filling with water carry out the first treatment of water by using chlorine preparations, including chlorine stabiliser. By doing so you will remove bacteria, algae, viruses and organic impurities from the pool water. If the filling lasts for several days, it is necessary to carry out the treatment operation at the end of the first day of filling. If water acquires a brownish colour, it means that the water includes iron and manganese (usually this concerns a well water). These substances react with the chlorine added and start to coagulate in an insoluble form and mostly they are trapped on the filter. During the first days after filling it is not necessary to regulate the pH value but within one week from filling it is necessary to identify its value (by means of a testing kit or through a professional laboratory) and to modify it by adding preparations for pH value correction. In the period when the pool is regularly used it is necessary to check and regulate the water condition at least once a week. Regular measurement and regulation of the pH value, disinfection and algae creation prevention will ensure that your water will be clean and sanitary.

Water source

We recommend you to check the water source before filling the pool (soft water may have corrosive effects and damage the pool equipment, on the other hand well water may include minerals which leave stains or sediments).

A natural characteristic of water is dissolution of minerals (hardness) – soft water in the pool tries to satisfy this from the sources which are available – from pumps, ladders, etc. As a source of water for your pool, please **DO NOT USE SOFT WATER ONLY**, always mix it with water which is more rich in minerals.

In order to eliminate the creation of stains caused by trace elements in water, we recommend you to add preparation for water hardness stabilisation.

Filtration and mechanical cleaning of the pool

By means of regular filtration it is possible to remove floating impurities from water. Carry out filtration only at the time when the pool is not used.

It is possible to avoid any excessive contamination of the pool with rough impurities (leaves, insects, sand, etc.) as well as with algae especially in such a way that you will cover the pool with a cover sheet at the time when it is not used. The quantity of impurities can be reduced also in such a manner that the surroundings of the pool is treated accordingly or that people will enter the pool across a tray or a little paddle pool with clean water. Remove these mechanical impurities either by using a hand collector (netting for the trapping of impurities) if they are floating in water or on the water level, or by using an exhauster if they are settled on the bottom. In the case of an excessive contamination of the bottom we recommend you to use the exhausting mechanism out of the pool and to replace the water drop with clean water.

Working with the exhauster

Note: The pool exhauster does not form a part of the pool. Please contact your seller.

The exhauster serves for removing the impurities settled on the bottom with the help of filtration equipment. The water stream is pumped by a pump with the help of a hose and the exhauster head into the filter where the impurities are caught.

- A. Remove the skimmer locking top. Switch the filtration unit valve to the position for filtration and turn on the filtration unit.
- B. Fill the exhauster hose with water (e.g. with a water stream from the return fitting).
- C. Hold the free hose end under the water level and connect the plate to it. Wait until the water stream starts flowing from the plate and then insert the plate quickly into the skimmer housing and install it firmly above the skimmer basket. While installing the plate into the skimmer, make sure not to interrupt the water column in the hose and that the first end of the hose is immersed in water for all the time.

Note: If you want to use the exhauster adapter, it is necessary to proceed with the following change:

1. Remove the skimmer locking top and remove the overflow system flap weir (carefully in order to avoid any damage to the flap weir). Insert the plate with the adapter installed (the adapter orifice must remain submersed below the water level so that the filtration unit can draw water) and direct the adapter towards the pool. Switch on the filtration unit.
 2. Fill the exhauster hose with water (e.g. with a water stream from the return fitting), and install the other end on the adapter inside the skimmer. While doing so, be sure that both the ends remain below the water level.
- D. Connect the pool exhauster onto the opposite end of the hose (which must be below the water level for all the time).
 - E. Now you can start using the exhauster. While exhausting, make sure that the exhauster head does not get above the water level and that the suction system does not get aerated. Draw impurities from the bottom slowly, as any sharp movement of the exhauster will cause whirling of the impurities settled.
 - F. After termination of the suction phase please disconnect the hose from the plate and remove the plate from the skimmer housing.

At the end of the suction phase we recommend you to check the filtration condition, whether it is not necessary to carry out the cleaning of the filter.

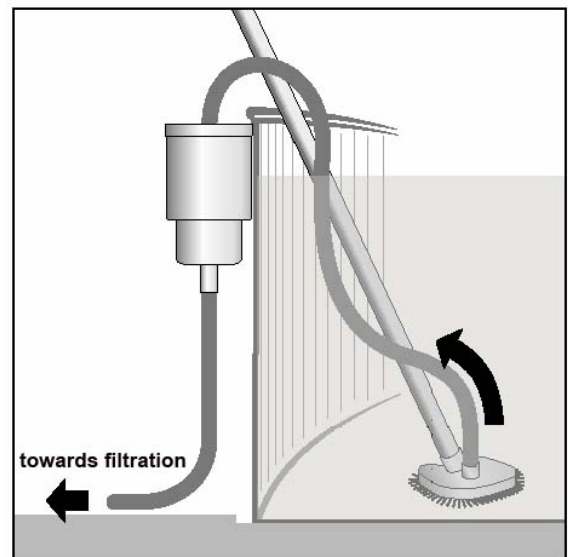

Measurement and pH value treatment

The pH value influences the correct function of the equipment, efficiency of other preparations and lifetime of the pool. The pH value must be checked at least 1-2x a week (by a measurement set) and immediately it is necessary to regulate deviations from the ideal value. We consider the solution with pH value 7 as neutral, up to 7 as acid and above 7 as alkaline. Water for taking a bath should have a pH value 7.2-7.6. Within this range it is possible to rely on the greatest efficiency of chlorine without any side effects. The pH value exceeding 7.6 can cause milky cloudiness in water (flocculation of calcium, iron, manganese in the form of hydroxides), filter clogging, reduction of chlorine preparation efficiency, chlorine odour, irritation of eyes and skin, reduction of disinfection effects – growth of bacteria and algae. If the pH values are up to 6.8, it may result in an increased corrosion of metals, paling the colours of plastic parts of the pool as well as in irritation of eyes and skin.

Water disinfection

Disinfection is the most important part of water maintenance because it is only elimination of micro-organisms that will ensure sanitary and clean water. Measure the chlorine content once a week, or more often in the case of heavy operation and in the season of hot weather. An ideal chlorine content is 0.5 mg/l. Before measuring the chlorine content please check and possibly treat the pH value. In the case of a stabilise operation use tablets or slow-solubility granules. By using a chlorine stabiliser it is possible to reduce the consumption of chlorine preparations. In the case of extreme conditions of the pool operation (high temperature, heavy load of the pool by swimming people, etc.), possibly if water has a non-standard quality (colour, odour, etc.), we recommend you to apply a shock disinfection.

Algae formation prevention

Algae appear as mucous sediments of various colours, accumulating on the walls and on the bottom of the pool and they support the growth of bacteria. Algae formation is acute especially during hot weather lasting for several days, frequent rains and storms. The spores of the algae are transmitted into the pool with the wind and dust, and they develop through the effects of UV radiation and hot water. Regular preventive doses of an anti-algae preparation are the best and the easiest method of how to prevent algae formation. People often use blue stone (copper sulphate) against algae, but this substance is classified amongst other poisons. Its use cannot be recommended especially for health reasons because it affects the blood count.

Flocculation, pool cleaning, etc. belong among complementary activities.

Water flocculation (clarification, coagulation)

Sometimes it may happen that even if the pH value and chlorine concentration are satisfactory, water will become quenched. This quenching is caused by microscopic particles, which the filtration equipment is unable to trap. In this case it is necessary to clean the water through flocculation when even microscopic particles start to merge and flocculate into larger wholes – flakes, which an already been drawn through the pool exhauster to an area out of the actual pool, possibly to filter out in the case of a small quantity.

Pool cleaning

During the season it is possible to see that various impurities settle on the wall of the pool – skin fat, cosmetics and sunbathing creams, sweat, dust, insects, leaves, seeds, grass straws, impurities from air and pool surroundings, as well as water hardness settled down. Even these impurities form a suitable source for formation of algae and bacteria. That is why it is recommended to properly clean the pool liner once a year, best in spring before water filling.

At the time of holidays

If you leave for your summer holiday and want to use your pool again after coming back, without having to clean and fill it again, it is necessary, before your departure, to adjust the pH value at 7.2-7.6, to add a triple amount of slowly soluble chlorine tablets into the chlorine dispenser or floater, and to cover the pool with a cover sheet. Then it is necessary to ensure the turning on of the filtration equipment during the day for at least 8 hours. After coming back, we recommend at first to put the filtration equipment into a continues operation, to check the pH value and the chlorine content.

IMPORTANT INSTRUCTIONS FOR THE USE OF CHEMICAL PREPARATION

1. While selecting chemical preparations, consider the purposefulness of the substance and possibility of use.
2. Make sure that the pool chemical agents purchased are not dangerous substances. Store them OUT OF THE REACH OF CHILDREN, in a cold, dry and dark place.
3. Get acquainted immediately with the first aid principles for any preparation, adhere to safety instructions and warnings on the packages.
4. While applying chemical preparations, proceed according to the manufacturer's instructions.
5. While handling the chemical preparations, adhere to the principles of personal hygiene. Use rubber gloves. At the end wash your hands carefully.
6. Do not insert any chemical preparations into the skimmer basket. For the purpose of chlorine preparation application in the form of tablets we recommend you to use the floater which is specially designed for this purpose, or a chlorine dispenser. If you buy a floater, insert the corresponding quantity of tablets into the floater and let it float on the water level. If you turn on the filtration equipment you will support faster dispersion of chlorine in the entire volume of the pool. After dissolution of the preparation please remove the floater and store it on a safe place. If you want to use the pool still before the dissolution of the preparation, please remove the floater and store it at the place where chlorine cannot cause any injury or damage. Protect it with special care from children.
7. **Do not use the pool at the time of application of any chemical preparations.**

In connection with water treatment with the help of chemical agents it is not possible to provide any general instructions for dispensing and treatment mode. The situation of every pool is different according to the nature of the pool, visitor's rate, surrounding environments, climatic conditions, etc. Dispensing must be governed by real values measured. That is why it is purposeful to buy the kit for measurement of pH and free chlorine. According to the measurement results it is possible to dispense the chemical preparations exactly. By doing so you will eliminate the danger of useless exposition of your organism with chemicals.

WHAT TO DO IF ...

Symptom	Cause:	Remedy:
Water is quenched	<ul style="list-style-type: none"> • Excessive formation of bacteria due to the high frequency of use of the pool, high temperatures, heavy rains, accumulation of impurities, etc., • Reduced filter capacity 	<ul style="list-style-type: none"> • Adjust the pH value at 7.2 – 7.6, • Apply "shock" disinfection, • Clean the filter • Add flocculant and filter continuously,
Water is misted in a green colour, the pool walls and bottom are mucous	<ul style="list-style-type: none"> • Excessive formation of algae 	<ul style="list-style-type: none"> • Adjust the pH value at 7.2 – 7.6, • Apply "shock" disinfection, • Apply the anti-algae solution, filter it continuously
Water is brown	<ul style="list-style-type: none"> • Water contains an excessive concentration of iron or manganese 	<ul style="list-style-type: none"> • Adjust the pH value at 7.2 – 7.6, • Apply "shock" disinfection, • Apply flocculant, filter continuously
Heavy, unpleasant chlorine odour	<ul style="list-style-type: none"> • Excessive pH value 	<ul style="list-style-type: none"> • Adjust the pH value at 7.2 – 7.6, • Check, possibly adjust the chlorine content.
Irritation of eyes or skin	<ul style="list-style-type: none"> • Incorrect pH value 	<ul style="list-style-type: none"> • Adjust the pH value at 7.2 – 7.6.